

## **Cam switches**

Cam switches series S 6 – 160 J	D 3
Rotary switches S 32, 250, 400 J	D 50
Compact power switches K 16 J a K 32 J	D 54
Controls	D 58
Switches in embedded box	D 59
Crane switches	D 61

# Notes

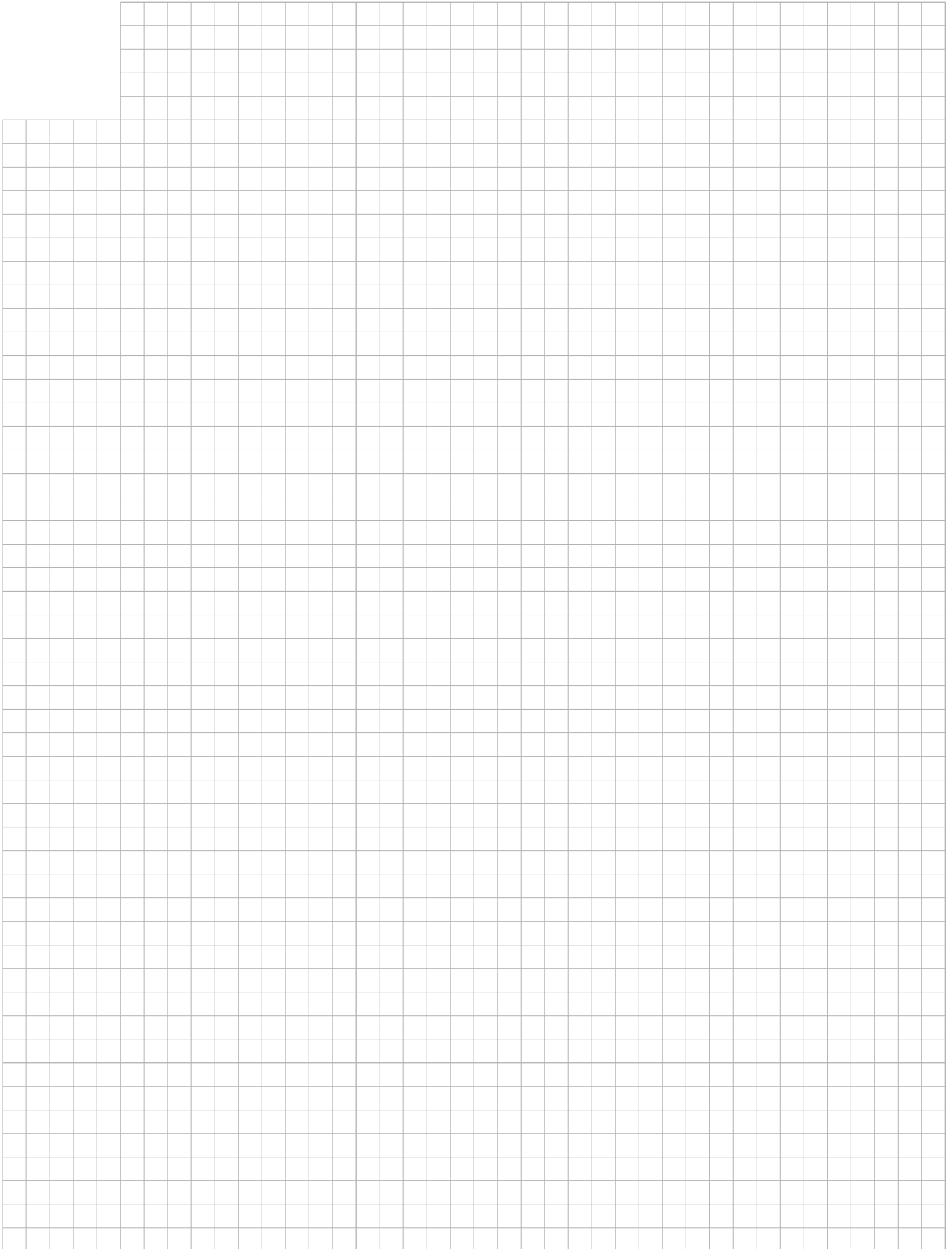

## General

Cam switches series S 6, 10, 16, 25, 32, 40, 63, 100, 160 J are a new generation of switches in current line from 6 to 160 A. They are divided to five sizes:

- size I** switches S 6, 10 J - size of the switching element 34x33x(10,5) mm
- size II** switches S 16, 25 J - size of the switching element 43x43x(13,5) mm
- size III** switches S 32, 40 J - size of the switching element 56x53x(16) mm
- size IV** switches S 63 J - size of the switching element 66x66x(18,5) mm
- size V** switches S 100, 160 J - size of the switching element 77x84x(21) mm  
(The number in parenthesis is a height of one switching chamber)

Cam switches in IV. and V. size have identical detent room  $\varnothing$  66 mm and fixation on the panel.

### CAM SWITCHES SERIES S..J :

- they are in accordance with EN 947-3, (EN 60 947-3, IEC 60 947-3), EN 60 204-1, VDE 0660
- all terminals and interconnection are protected against contact (IP20)
- all execution are produced to reach the protection mode of IP 65 with delivery of the sealing elements designed with G to seal the shaft and fastening screws
- the cam switches in size I. - IV. have entrance to terminals with screwdriver in angle 45° and corrected readability of terminals designations on skewed area too
- switching angle: 30°, 45°, 60° and 90° (preferential angle 60° - maximum 6 switching position; angle 30° - maximum 12 switching position)
- small and unification switch sizes
- flexibility of mechanical execution
- extended selection of electrical execution by catalog
- maximum number of the switching chambers is 12 (24 contacts)
- they are in accordance with T32 requirements and they meet surrounding temperatures from -30° to +55°C.

## Application

Power switches for switching of motors with load in AC3, AC23  
 Switches in the auxiliary and measuring circuits  
 Connection of the resistance loads and electric furnaces  
 Stage change-over switches of the transformers, welding machines...  
 Switches with reversible position for testing purposes and single-phase motors  
 Change-over switches, switches of Y D , poles switching (speed) of multirevolution motors

## Type designation

**S XXX J XXX XXXX XXX/XX XXX XXX**

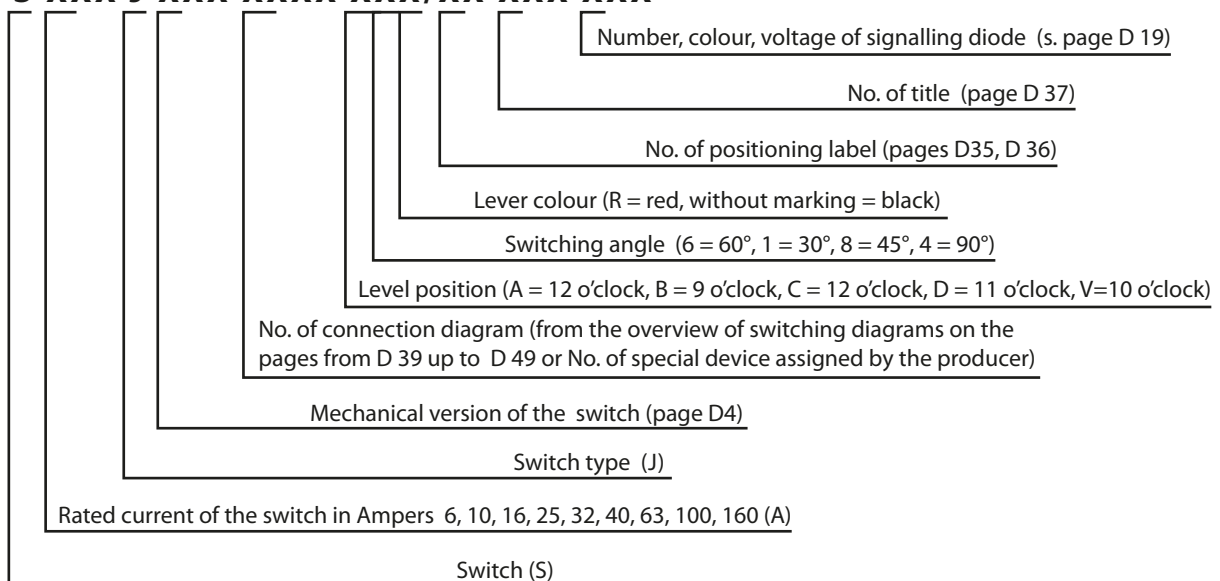

## Order example:

S16JVDG 2203X A6 R/ 01 N01 1R4

As an example, the following cam switch is specified:

- cam switch with rated current 16 A
- with reversible position (V), with frontal plate (D), with rubber insulation for IP65 (G)
- three - pole switch (2203) without interconnector (X)
- basic position of the lever A (12 hod), switching angle 60° (6)
- red lever (R)
- label position 01 with inscription MASTER SWITCH
- switch with 1 indication diode (red) for voltage 230 V~

When specifying the switch, is necessary use the base catalog with mechanical and electrical charts.

For substandard version of switch is necessary supply the specification sheet and send it to producer.

When no required position, switching angle, label position or inscription is stated, the A lever position (12 Hours), switching angle of 60° or other

regarding to required switching programme and relevant position label will be determined by the producer.

Label, inscription and LED diode No. are to be stated if they are resulted from mechanical execution and they are required specifically. (Type designation up to vertical dividing line).

## Mechanical Execution

Switch with fixing to the panel (front mounting)

Type designation	Execution description
S ... J	With lever (without frontal plate)
S ... JE	With handle and terminal pins
S ... JG	With lever and rubber insulation for IP 65
S ... JD	With lever and frontal plate
S ... JZ	With the zero position (or other required positions -cite) to be locked with propelling lock
S ... JU	Switch with possibility to be locked by 3 padlocks
S ... JF	Switch with light alarm (1-3 LED diodes)
S ... JV	Switch with one or two reversible positions (only switch S 6 - 25 J)
S ... JR	Central fixing of the switch to the hole of 22 diameter with control by lever (only S 6 - 25 J)
S ... JK	Central fixing of the switch to the hole of 22 diameter with control by key (only S 6 - 25 J)
S ... JT	Switch with inhibiting push-button in zero position (only S 6 - 25 J) - other position cite
S ... JC	Switch with undervoltage coil 230 V~ (only for S 63 J)

Switches with rear fixing (reversed mounting)

Type designation	Execution description
S ... JO	Rear fixing of switches (reversed mounting)
S ... JLD	Switch with frontal plate fastened to the strip TH 35-7,5
S ... JLS	Switch fastened to the strip TH 35-7,5, with label 52,5x45 mm (only S 6, 10, 16, 25 J)
S ... JB	Rear fixing of switch - with lever in the door
S ... JBD	- with lever and frontal plate in the door
S ... JBU	- with lockable lever in the door
S ... JBZ	- with propelling lock in the door
S ... JP	Switch in the box with lever (IP65)
S ... JPD	Switch in the box with frontal plate (IP65)
S ... JPU	Switch in the box with lockable lever (IP65)
S ... JPZ	Switch in the box with propelling lock (IP65)
S ... JA	In Al cover (S 16 - 63 J)
S ... JAZ	In Al cover with propelling lock (S 16 - 63 J)
S ... JI	In Al cover with 3 fuses (S 16 - 63 J)
S ... JIZ	In Al cover s 3 fuses and propelling lock (S 16 - 63 J)
S ... NJ	In cover from plastic material with 3 fuses (S 16 - 25 J)
S ... NJU	In cover from plastic material with 3 fuses and lockable level 1 - 3 padlocks (S 16 - 25J)
S ... NJZ	In cover from plastic material and 3 fuses and propelling lock( S 16 - 25J)
S ... JM	With small lever
S ... JH	With locking lever S 6 - 25 J

**Notes:** All mechanical executions of switches are each other compatible, e.g. S16JVDG is switch of 16A rated current, with reversible position (V), frontal plate (D) and rubber insulation (G) for IP65. Executions JV, JR, JK, JLS are only available for switches of size I, II.

## Technical data

Type of switch	S6J	S10J	S16J	S25J	S32J	S40J	S63J	S100J	S160J	
Rated insulation voltage $U_r, V^*$	500	500	690 **	690 **	690	690	690	690	690	
Impulse withstand voltage $U_{imp}, kV$	4	4	4	4	6	6	6	6	6	
Rated thermal current $I_{th}, A$	6	10	20	25	32	40	63	100	150	
Rated operational current $I_e, A, AC-21A; AC-1$	6	10	16	25	32	40	60	100	150	
Rated operational power, kW / rated operational current $I_e, A$										
AC-3 short armature motor ; starting, stopping	1 phase 220-240V	0,9/5,1	1,5/8,5	1,7/9,6	2,6/14,7	4/22,7	4,4/25	5 / 28,4	10 / 56,8	13 / 73,8
	3 phase 220-240V	1,5	2,5	3	4,5	7	7,7	8,5	17	23
	380-440 V	2,5/4,5	3,5 / 6,3	4 / 7,2	7,5 / 13,5	12 / 17,3	13/18,8	15 / 27	30 / 54	40 / 72
	500 V	2,5	3,5	4	7,5	12	13	15	30	40
AC-23A switching of motor and high inductive loads	1 phase 220-240 V	1/5,5	1,7 / 9,6	2,3 / 13	3 / 17	6,8/32	7,3/40	10 / 56,8	13 / 73,8	18 / 102
	3 phase 220-240 V	1,8	3	4	5,5	10	12,5	17	23	30
	380-440 V	3,3/6	5,5/10	7,5 / 13,5	11 / 19,8	17,5/32	22/40	30 / 54	40 / 72	55 / 99
	500 V	3,3	5,5	7,5	11	22	27	30	40	55
Rated DC operational current $I_e, A$										
- DC	24 V	6/4	10/8	16/8	25/8	32/12	34/12	63/25	100/32	150/63
(one switching contact)	48 V	3,7/2	6/4	6/4	6/4	25/10	25/10	25/16	32/20	32/20
DC-21A/DC-22A	110 V	0,7/0,2	1/0,3	1/0,3	1/0,3	4/3	4/3	4/3	5/4	5/4
(resistive load/DC motors)	220 V	0,2/0,1	0,3/0,2	0,3/0,2	0,3/0,2	1/0,4	1/0,4	1/0,4	1,2/0,5	1,2/0,5
Rated conditional short circuit current $I_{cn}, kA$	3	4	5	5	10	10	8	10	10	
with fuse gG, A	6	10	16	25	32	40	63	100	160	
Rated short time withstand current - 1 sec $I_{cw}, A$	160	200	220	500	800	1000	1200	1500	2000	
Rated short circuit making capacity $I_{cm}, A$	320	400	400	500	800	1000	1200	1500	1600	
Mechanical endurance (operations)	106	106	106	106	3x105	3x105	3x105	3x105	105	
Terminals, mm <sup>2</sup>	0,5-2,5	0,5-2,5	1-4	1,5-4	2,5-10	2,5-10	6-16	16-50***	16-50***	
Terminal screw	M3	M3	M4	M4	M5	M5	M5	M6x0,75	M6x0,75	
Control winch	● 5	● 5	● 5	● 5	● 5	● 5	● 6	● 6	● 6	

### Note.:

\*STN EN 330420 - for circuits with grounded neutral point, category of overvoltage III and degree of pollution 2 ;

$U_i=500V$ , if degree of pollution 3

\*\*Main switch (execution S...JU) reduction of  $U_i$  to 400 V

\*\*\*for 1 rigid Cu wire - max size 70 mm

## Dimensional drawing - comparison of sizes S6 - S160 J

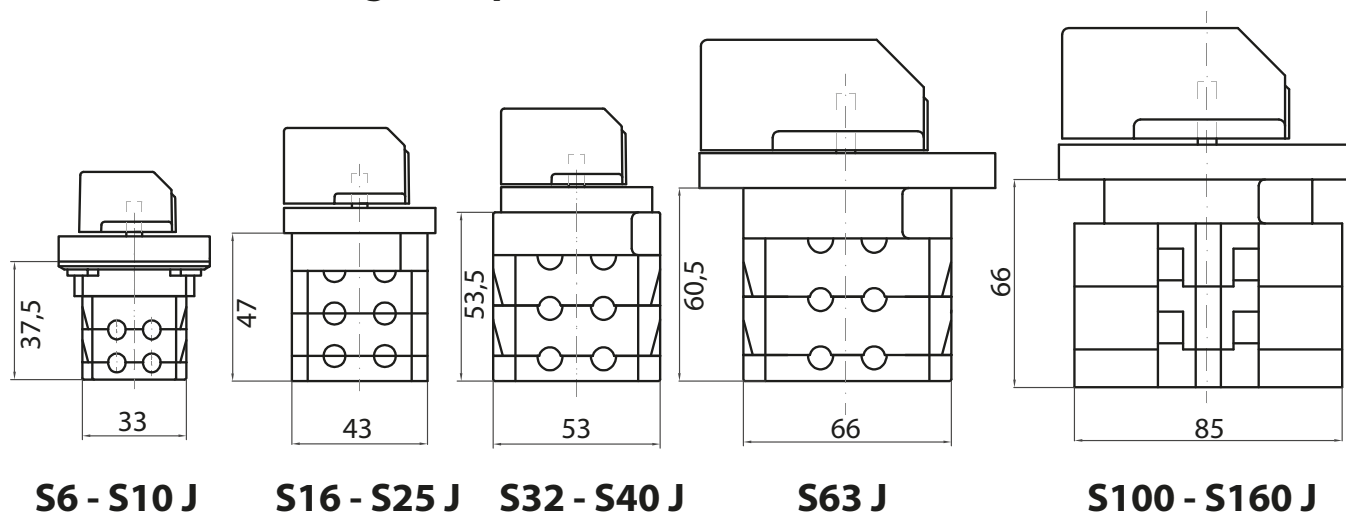

## PANEL MOUNTING SWITCHES

S ... J, JE, JD, JG, JZ, JU, JR, JK, JV, JT, JF, JC

### Dimensions (in mm)

Type	A	B	C	D	E	F	G	H	I	J	K	M	N	O	P	R	S	H1	U	V	X	Y	Z
S 6, 10 J	48	36	66	8	13	17,5	1,5	10,5	9	31	30	M3	23	3	19	30	34	5	5,5	33	15	3,2	46
S 16, 25 J	48	36	66	8	14	24	1,5	13,5	9	31	35	M4	23	3	24	30	43	5	5,5	43	19	4,2	46
S 32, 40 J	48	36	66	8	20,5	31	1,5	16	9	31	35	M4	23	3	24	30	56	5	7,5	53	19	4,2	46
S 63 J	94	75	106	11	22	46	2	18,5	10	42	50	M5	30	4	35	50	66	6	7,5	66	34,5	5,4	74
S 100, 160 J	94	75	106	11	22	46	2	21	10	42	50	M5	30	4	35	50	77	6	7,5	85	34,5	5,4	74

Type	L if no of chambers											
	1	2	3	4	5	6	7	8	9	10	11	12
S 6, 10 J	27,5	38	48,5	59	69,5	80	90,5	101	111,5	122	132,5	143
S 16, 25 J	33,5	47	60,5	74	87,5	101	114,5	128	141,5	155	168,5	182
S 32, 40 J	37,5	53,5	69,5	85,5	101,5	117,5	133,5	149,5	165,5	181,5	197,5	213,5
S 63 J	42	60,5	79	97,5	116	134,5	153	171,5	190	208,5	227	245,5
S 100, 160 J	45	66	87	108	129	150	171	192	213	234	255	276

## SWITCHES IN ENCLOSURES

S ...J, JO, JLS, JLD, JB, JBD, JBU, JBJ, JP, JPU, JPD, JA, JI, JAZ, JIZ, NJ, NJU

### Dimensions (in mm)

Type	A	B	C	D	E	F	G	H	I	J	K	M	N	O	P	R	S	H1	U	V	X	Y	Z
S 6, 10 J	48	36	66	8	13	17,5	1,5	10,5	9	31	30	M3	23	3	19	30	34	5	5,5	33	15	3,2	46
S 16, 25 J	48	36	66	8	14	24	1,5	13,5	9	31	35	M4	23	3	24	30	43	5	5,5	43	19	4,2	46
S 32, 40 J	48	36	66	8	20,5	31	1,5	16	9	31	35	M4	23	3	24	30	56	5	7,5	53	19	4,2	46
S 63 J	94	75	106	11	22	46	2	18,5	10	42	50	M5	30	4	35	50	66	6	7,5	66	34,5	5,4	74
S 100, 160 J	94	75	106	11	22	46	2	21	10	42	50	M5	30	4	35	50	77	6	7,5	85	34,5	5,4	74

Type	Z1	V1	S1	B1	B2	U1	U2	L1	L2	L3	D1	D2	D3	A1	F1	A2	C1
S 6, 10 J	22	110	87	66	73	5,5	10,5	86	100	159	64	14	8	72	35	48	66
S 16, 25 J	22	110	87	66	73	5,5	10,5	86	100	159	64	14	8	72	35	48	66
S 32, 40 J	30	160	140	110	110	6,5	12	108	140		84	16	10	119	58	66	106
S 63 J	30	160	140	110	110	6,5	12	108	140		84	16	10	119	58	66	106
S 100, 160 J	30	160	140	110	110	6,5	12	140			84	16	10	119	58	66	106

Type	T if no of chambers											
	1	2	3	4	5	6	7	8	9	10	11	12
S 6, 10 J	84	94,5	105	115,5	126	136,5	147	157,5	168	178,5	189	199,5
S 16, 25 J	90	103,5	117	130,5	144	157,5	171	184,5	198	211,5	225	238,5
S 32, 40 J	98	114	130	146	162	178	194	210	226	242	258	274
S 63 J	102,5	121	139,5	158	176,5	195	213,5	232	250,5	269	287,5	306
S 100, 160 J	105	126	147	168	189	210	231	252	273	294	315	336

Type	L4 if no of chambers											
	1	2	3	4	5	6	7	8	9	10	11	12
S 6, 10 J	70	70	70	70	112	112	112	112	154	154	154	154
S 16, 25 J	62	62	76	130	130	130	130	197,5	197,5	197,5	197,5	197,5
S 32, 40 J	112	112	112	112	169	169	169	253	253	253	295	295
S 63 J	115	115	115	115	172	172	172	256	256	256	298	298
S 100, 160 J	115	115	115	172	172	172	256	256	256	256	298	298

Type	Max. if no of chambers		
	L1	L2	L3
S 6, 10 J	3	4	9
S 16, 25 J	2	3	7
S 32, 40 J	2	4	-
S 63 J	2	4	-
S 100, 160 J	3	-	-

# CAM SWITCHES S ... J

switch with handle without frontal plate



**S 6,10 J**

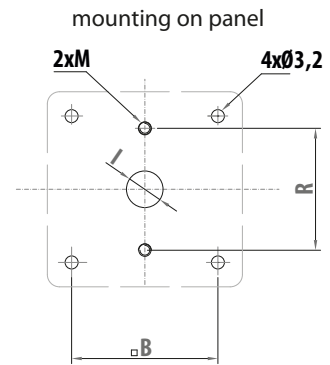
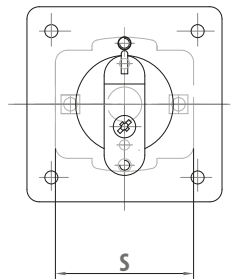
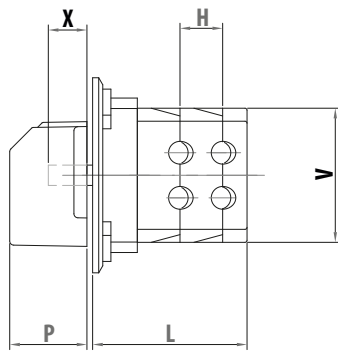

**S 16, 25, 32,40, 63 J**

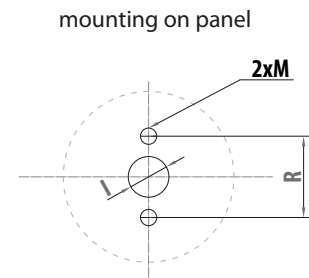
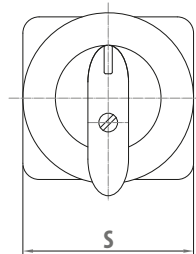
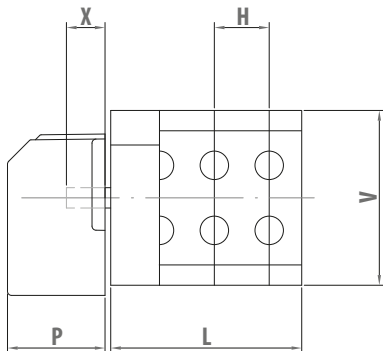

**S 100, 160 J**

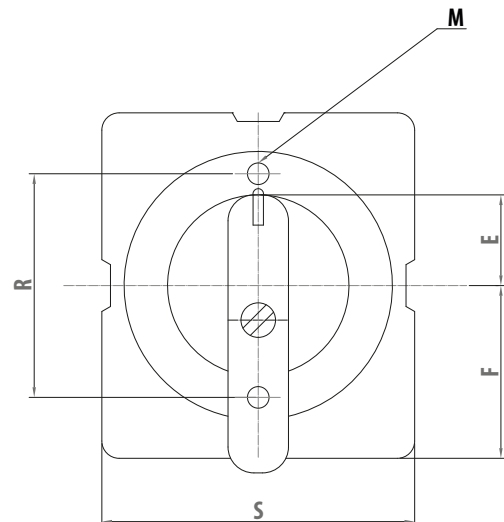
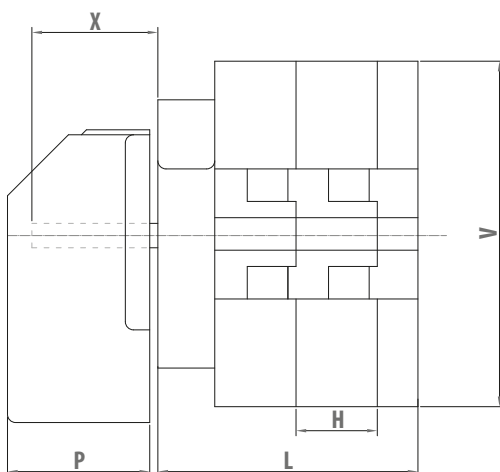

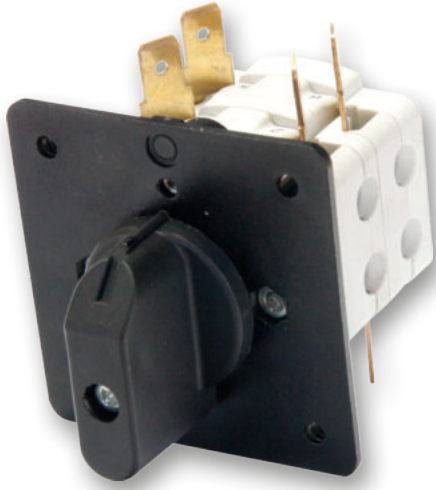

## CAM SWITCHES S ... JE

- switch with handle and terminal pins

S6, 10 JE

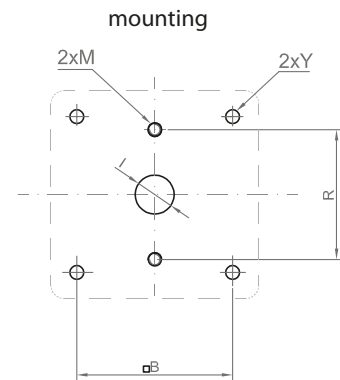
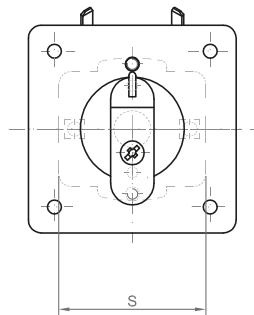
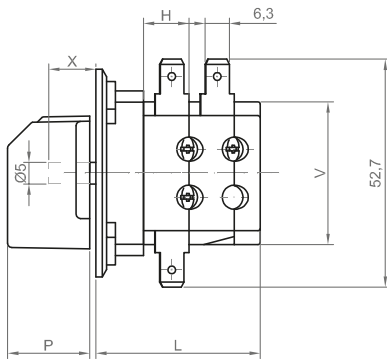

S 16, 25 JE

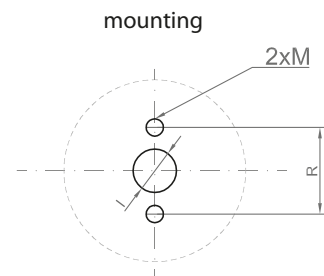
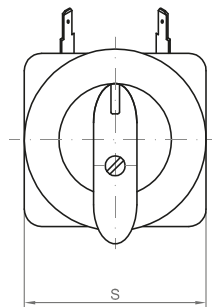
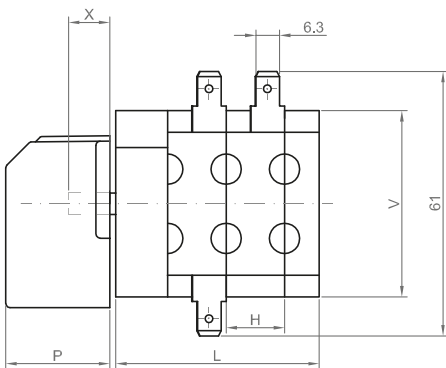



# CAM SWITCHES S ... JD

- switch with handle without frontal plate



S 6,10 JD

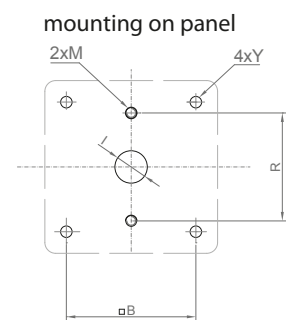
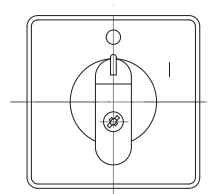
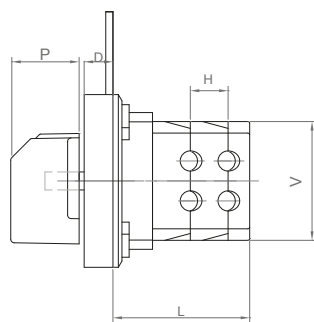

S 16, 25, 32, 40, 63 JD

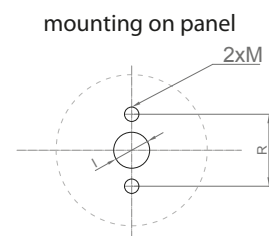
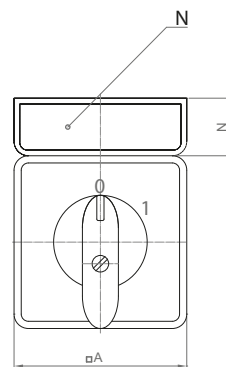
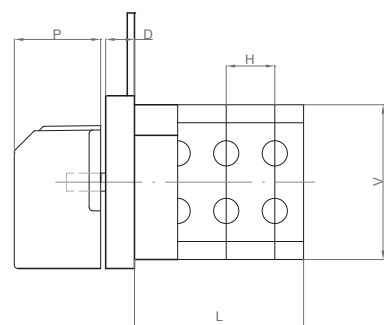

S 100, 160 JD

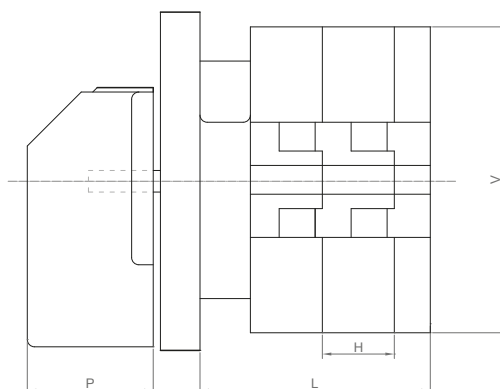

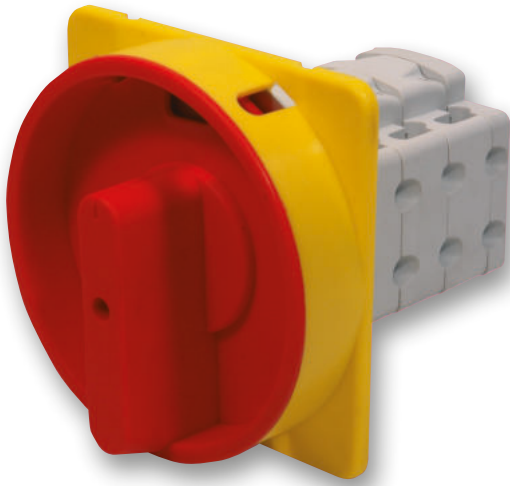

## CAM SWITCHES S ... JU

- switch with possibility to be locked by 3 padlocks (Ø 5-8 mm)
- switch as master or emergency switch

S 6,10 JU

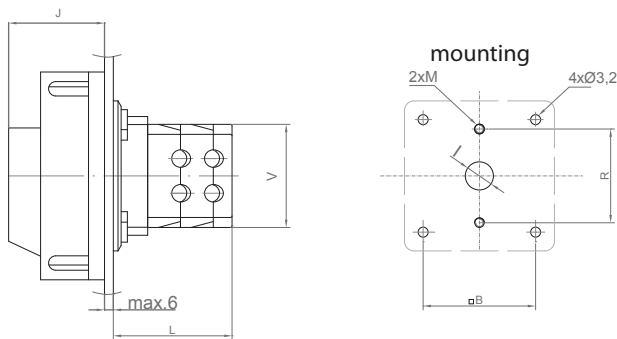

S 16, 25, 32, 40, 63 JU

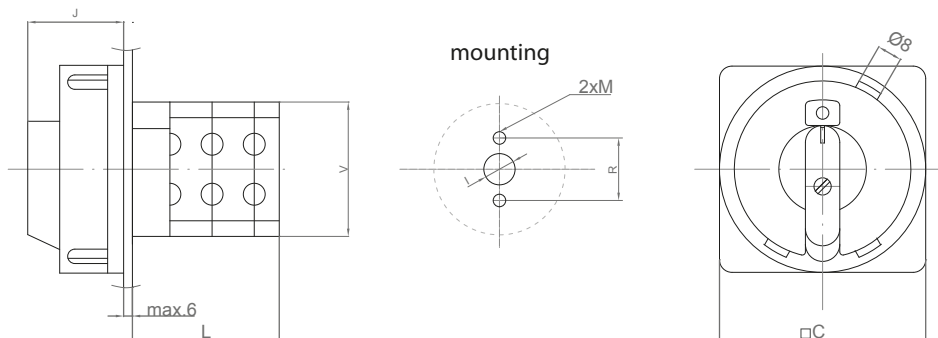

S 100,160 JU

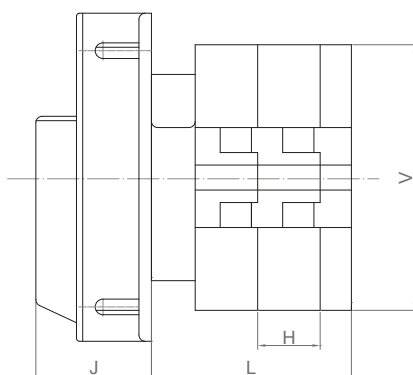

# CAM SWITCHES S ... JZ

- Switch with the zero position (or other required positions) to be locked with propelling lock



S 6,10 JZ

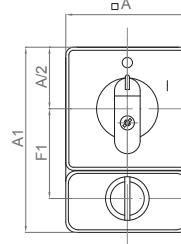
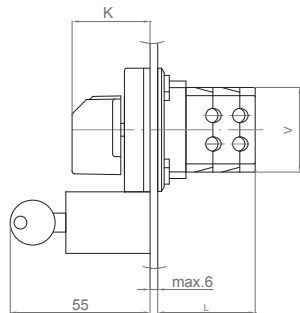

mounting on panel

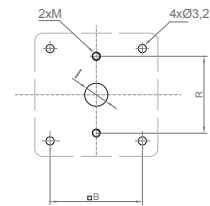

S 16, 25, 32, 40, 63 JZ

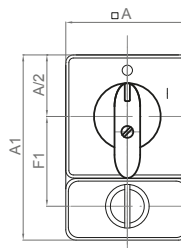
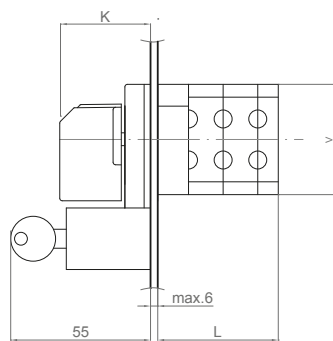

mounting on panel

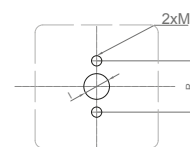

S 100, 160 JZ

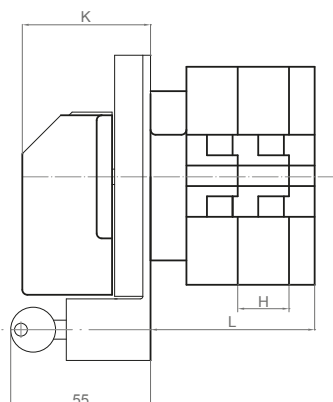



## CAM SWITCHES S ... JV

- Switch with one or two reversible positions also through more positions
- Maximum possible angle of reversible control 120°
- When specifying the switch, is necessary state (switches with two and more positions) the reversible and locking position, for example the switch with switching position 0-1-2 by move from position 2 to 1 is signify as V2-A1

Type	L (mm) if no of chambers											
No of chambers	1	2	3	4	5	6	7	8	9	10	11	12
S 6, 10 JV	38	48,5	59	69,5	80	90,5	101	111,5	122	132,5	143	154,5
S 16, 25 JV	47	60,5	74	87,5	101	114,5	128	141,5	155	168,5	182	195,5

S 6,10 JV

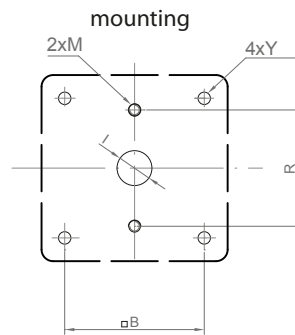
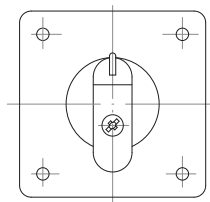
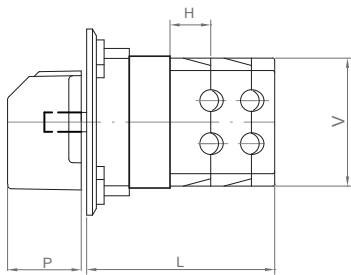

S 16, 25 JV

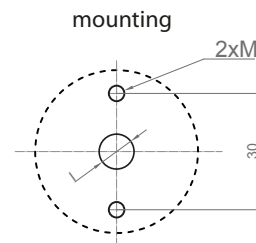
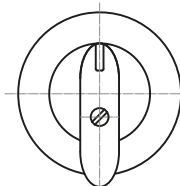
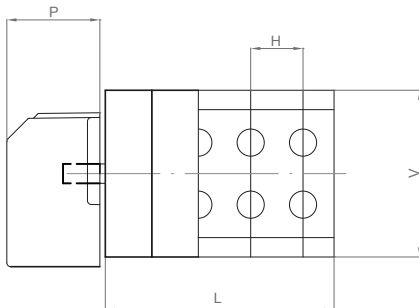

## CAM SWITCHES S ... JG

- Switch with rubber insulation for IP 65

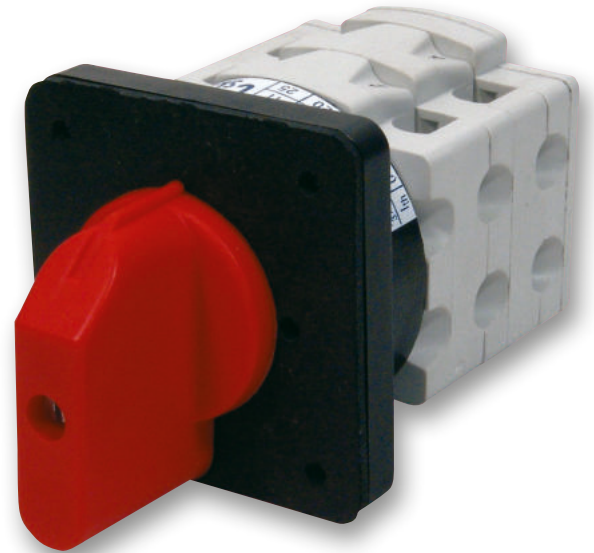

	S 6 - 10 J	S 16 - 40 J	S 63 - 160 J
A - Fixation by two self tapping screws	D3,5	D4	D4
B - Fixation by two bolts and nuts	M3	M4	M5

### S 6,10 JG

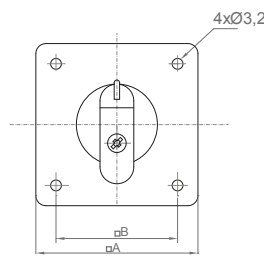
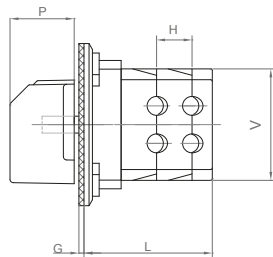

mounting on panel

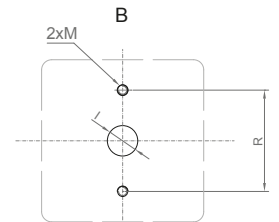
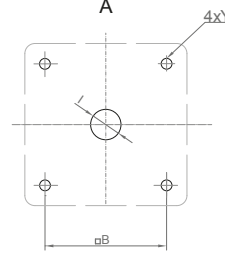

### S 16, 25, 32, 40,63 JG

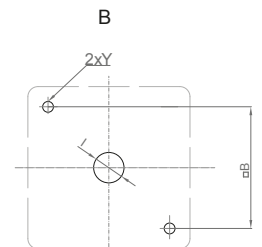
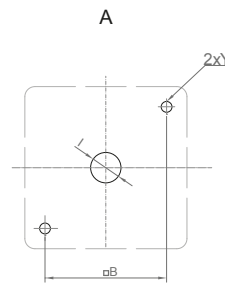
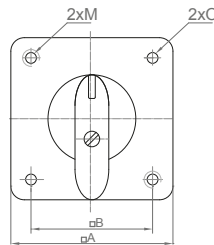
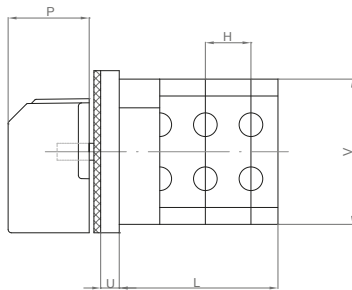

### S 100, 160 JG

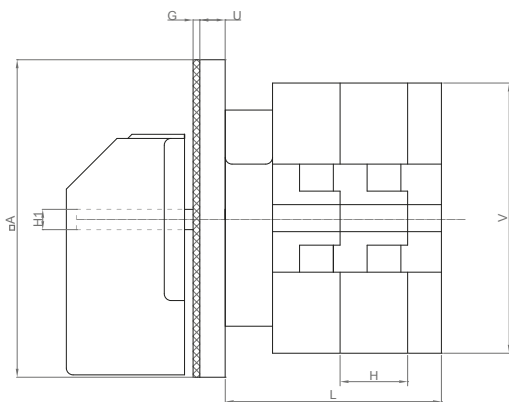

## CAM SWITCHES S ... JDG

- Switch with frontal plate and rubber insulation for IP 65



	S 6 - 10 J	S 16 - 40 J	S 63 - 160 J
A - Fixation by two self tapping screws	D3,5	D4	D4
B - Fixation by two bolts and nuts	M3	M4	M5

S 6,10 JDG

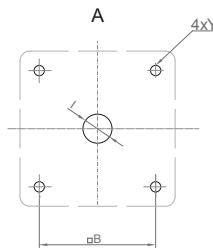
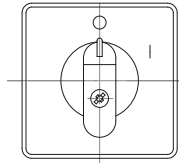
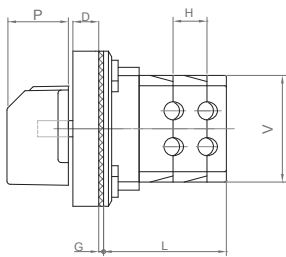

mounting on panel

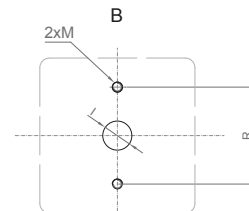

S 16, 25, 32, 40, 63 JDG

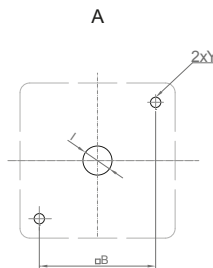
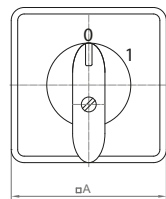
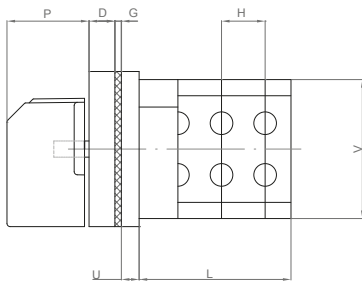

mounting on panel

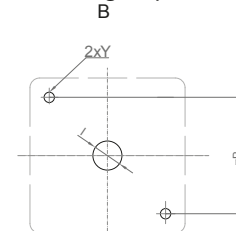

S 100, 160 JDG

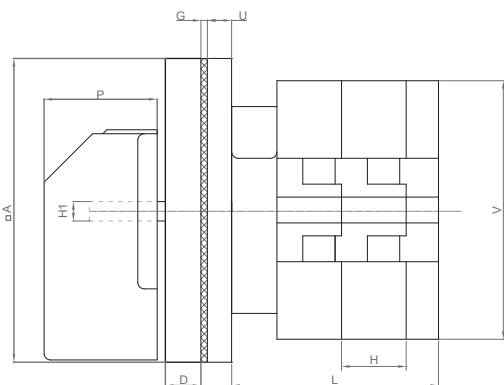

# CAM SWITCHES S ... JK

- central fastening cam switch to the  $\varnothing 22$  mm diameter hole using bayonet mechanism
- control by key



Type	L (mm) if no of chambers											
No of chambers	1	2	3	4	5	6	7	8	9	10	11	12
S 6, 10 JK	51,5	62	73,5	84	94,5	106	107,5	108	118,5	129	139,5	150
S 16, 25 JK	54,5	68	81,5	95	108,5	112	135,5	149	162,5	176	189,5	203

S 6,10 JK

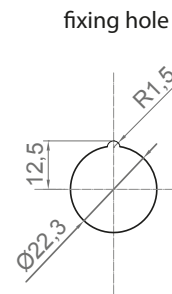
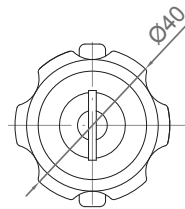
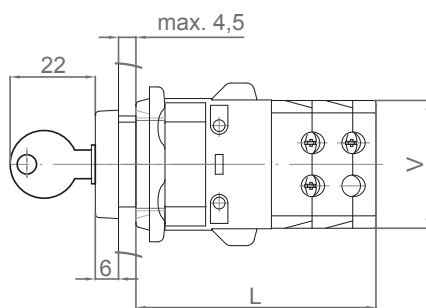

S 6,10 JKD

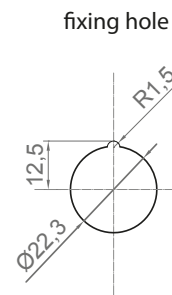
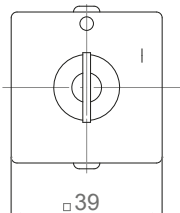
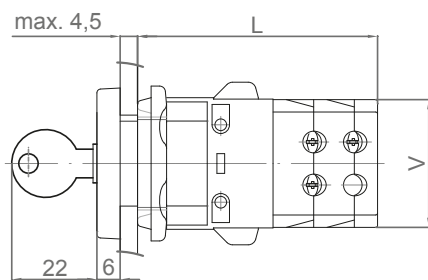

S 16, 25 JK

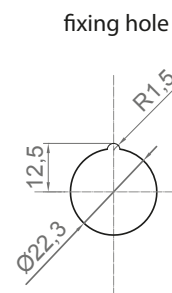
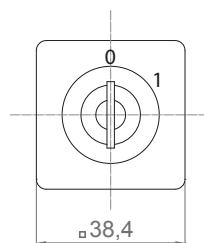
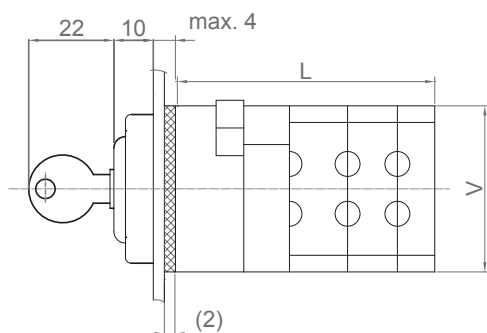



## CAM SWITCHES S ... JR

- Central fixing of the switch to the hole of  $\varnothing 22$  mm diameter, JRG : JR
- + rubber seal G
- Control by lever

Type	L (mm) if no of chambers											
No of chambers	1	2	3	4	5	6	7	8	9	10	11	12
S 6, 10 JR	51,5	62	73,5	84	94,5	106	107,5	108	118,5	129	139,5	150
S 16, 25 JR	54,5	68	81,5	95	108,5	112	135,5	149	162,5	176	189,5	203

S 6,10 JR

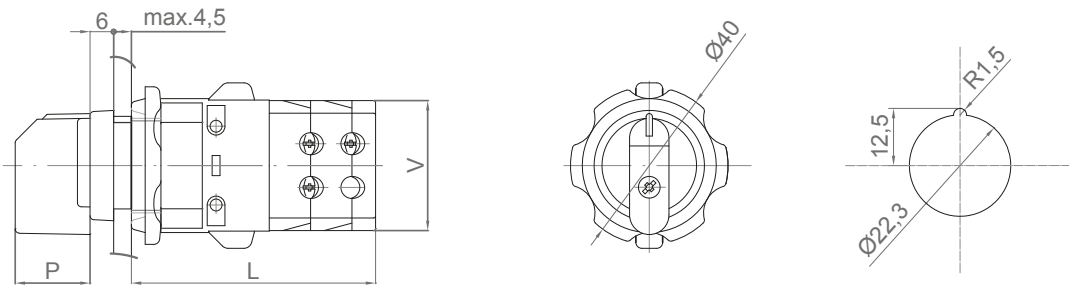

S 6,10 JRD

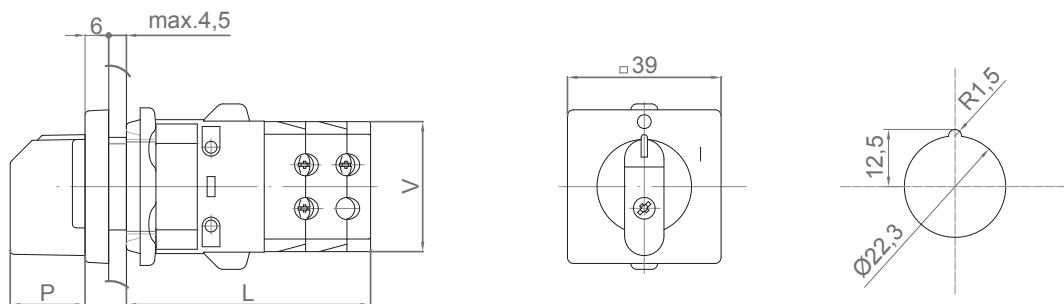

S 16, 25 JR

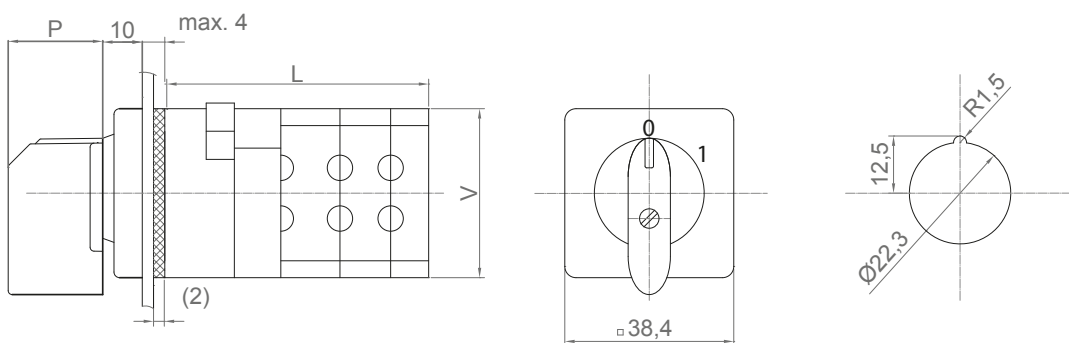



## CAM SWITCHES S ... JC

- switch with undervoltage coil (the switch switched off selfactually when the voltage in the inlet terminal is OFF)
- possibility of switching on from 85% Un and more
- possibility of switching off from 85% Un and less, necessity to switch off from 35% Un
- undervoltage coil terminals are marked as A1 - A2, coil voltage 230 V ~
- designed for second dimensional size 63 A
- mounting on panels, into enclosures
- advantage: no voltage on coil terminals of electromagnet in OFF position
- application: as 3 pole OFF switches - 1103 A6 as reverse changeover switches - 9151 C6

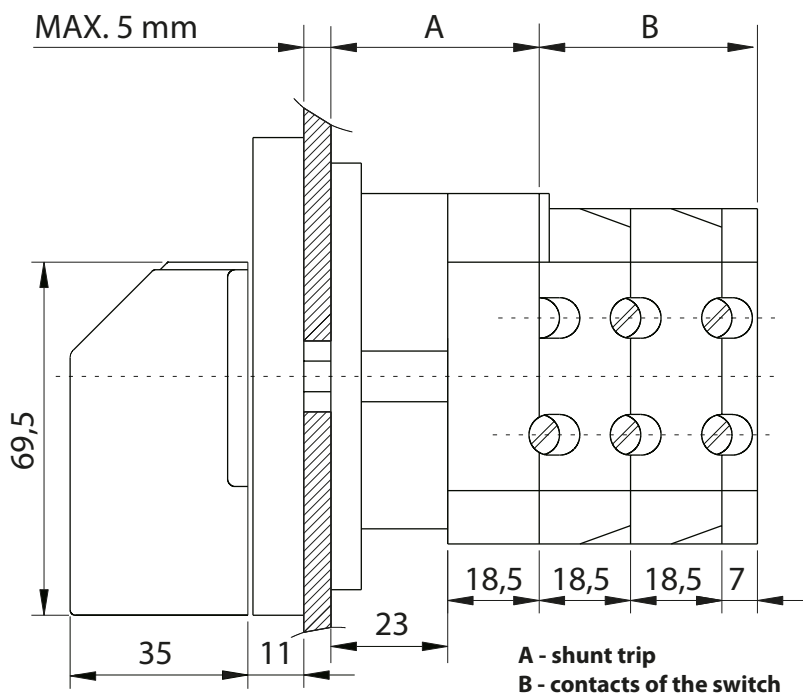
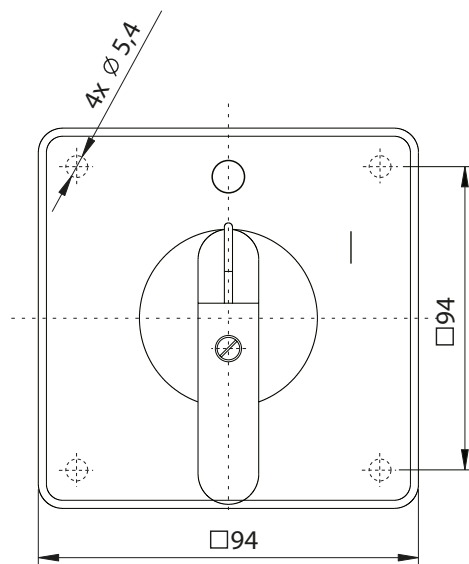

## CAM SWITCHES S ... JT

- switch with lever and frontal plate  
- switch with push button which blocks lever in zero position



S 6,10 JT

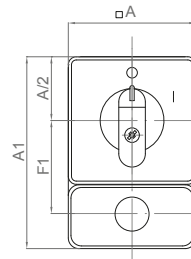
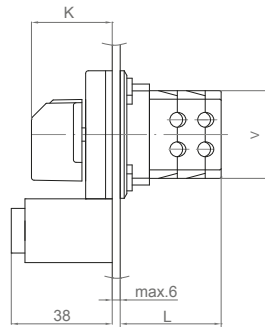

mounting on panel

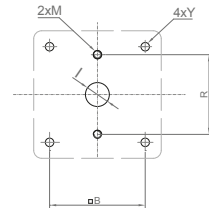

S 16, 25, 32, 40, 63 JT

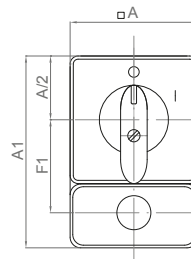
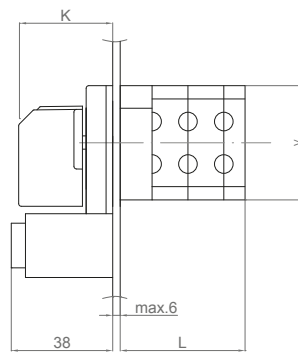

mounting on panel

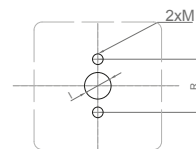

S 100, 160 JT

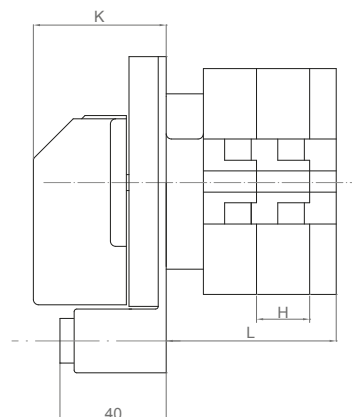

button: G - green  
R - red  
Y - yellow  
without marking - black

## CAM SWITCHES S ... JF

- Switch with light alarm in selected position



### Specification of LED diode

3 or 4-character code, at the end of the technical specification of switch (see „Order sheet example“ page D 2)

Example.:

**2 RG 0**  
 Feeding voltage of LED diode („24 V ~“ - see chart 2)  
 LED diode color two-tone („red/green“ - see chart. 1)  
 Number of LED diodes 2 (1, 2 or 3)

**2 R.G 0**  
 Feeding voltage of LED diode („24 V ~“ - see chart. 2)  
 LED diode color („red / green“ - see chart 1)  
 Number of LED diodes 2 (1, 2 or 3 pcs)

Colour	Symbol
Red	R
Green	G
Orange	E
Yellow	Y

**Other possible combinations (2-color LED diode): RG, YG, EG, EY**

Voltage	24 V	48 V	60 V	110 V	230 V
Alternative	0	1	2	3	4
Direct	5	6	7	8	9

**Note.:** LED diode constructors are connected to individual terminals at the end of the switch, other requirements, please consult with manufacturer.

JF

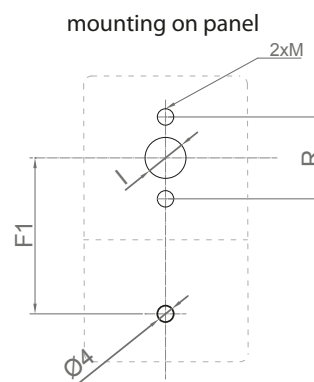
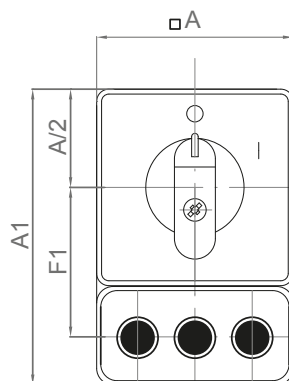

JZF

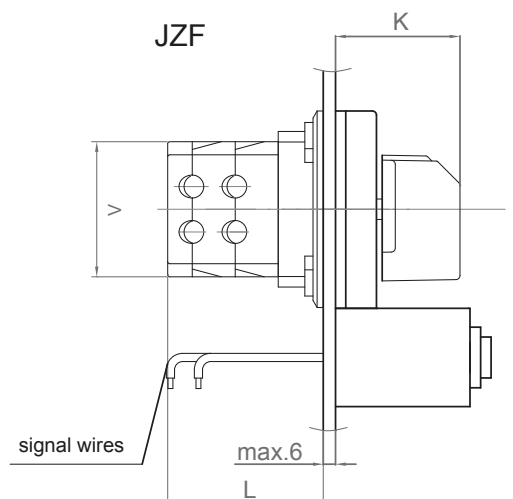

mounting on panel

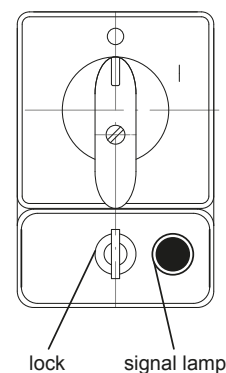



## CAM SWITCHES S ... JO

- switch with rear fixing

S 6,10 JO

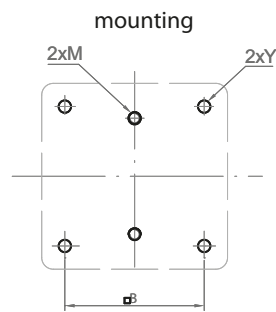
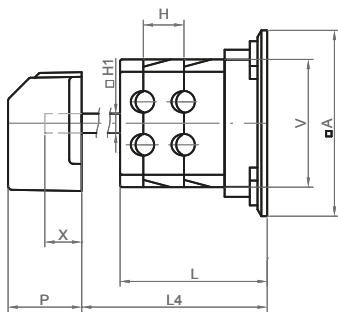

S 16, 25, 32, 40, 63 JO

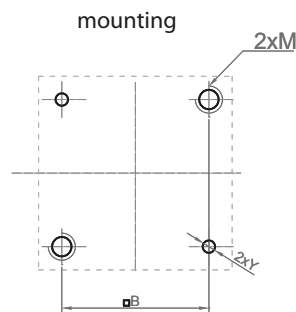
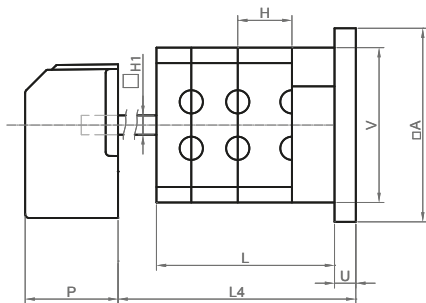

S 100, 160 JO

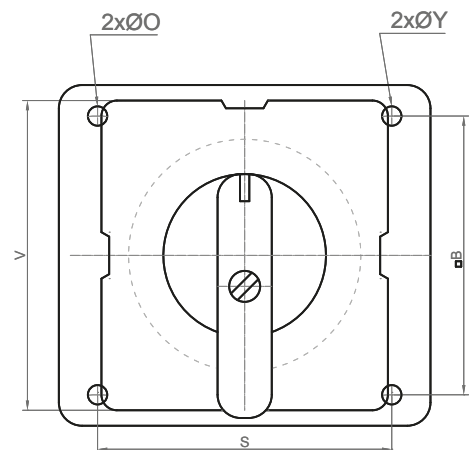
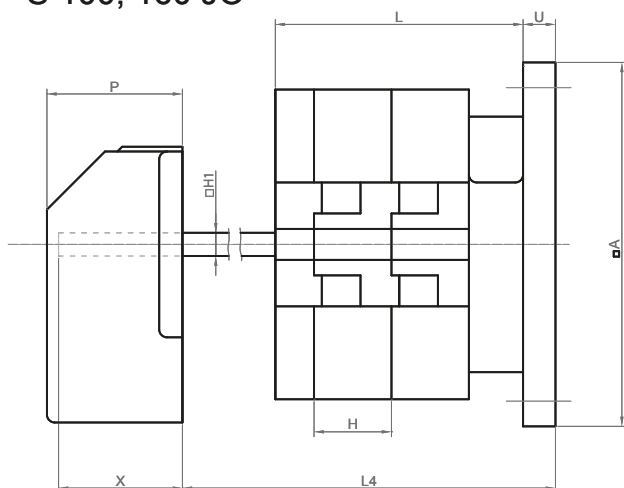

## CAM SWITCHES S ... JLS

- Switch mounted on rail TH 35 - 7,5 with label
- Execution JL with lever, without label

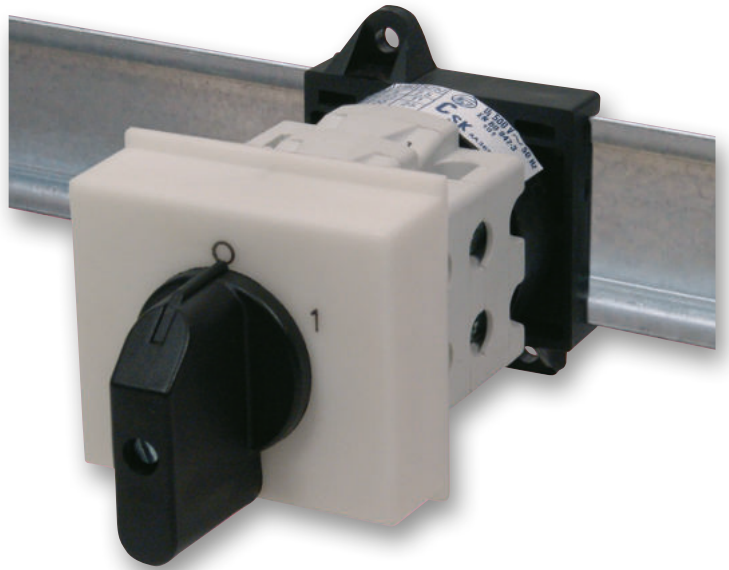

Type	L (mm) if no of chambers											
No of chambers	1	2	3	4	5	6	7	8	9	10	11	12
S 6, 10 JLS	39	52,5	66	79,5	93	106,5	120	133,5	147	160,5	174	187,5
S 16, 25 JLS	27,5	38	48,5	59	69,5	80	90,5	101	111,5	122	132,5	143

**S6,10 JLS**

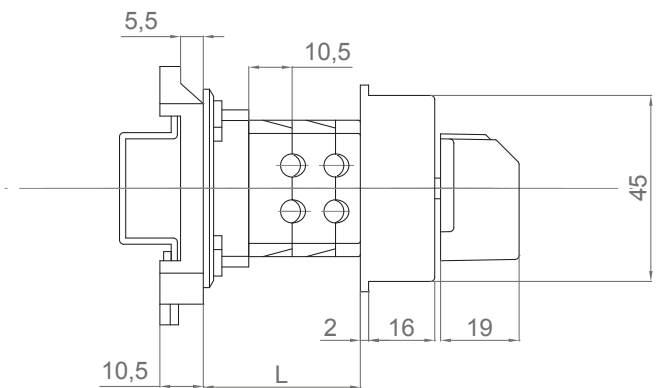
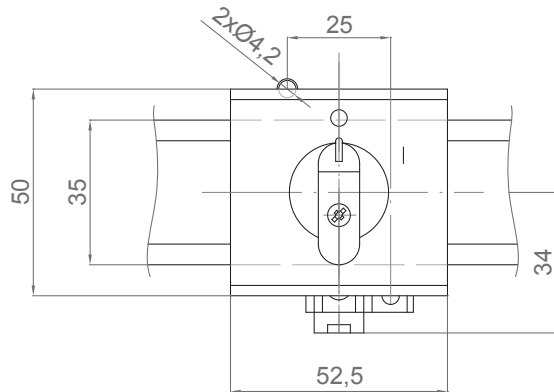

**S16,25 JLS**

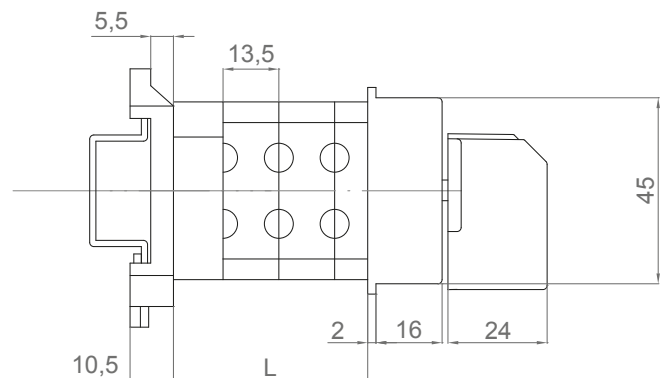
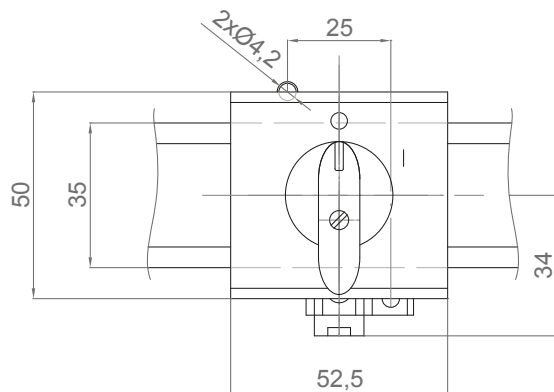



## CAM SWITCHES S ... JLD

- Switch mounted on rail TH 35 - 7,5 with frontal plate
- Execution JL with lever, without frontal plate

**S6, 10 JLD**

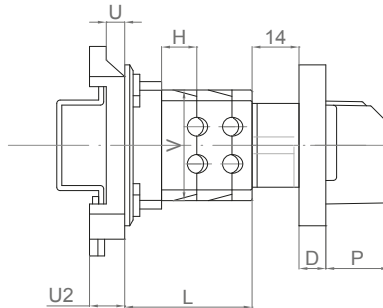
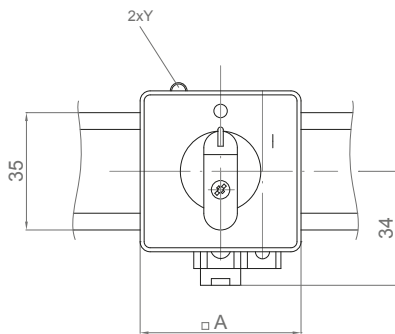

**S16, 25, 32, 40 JLD**

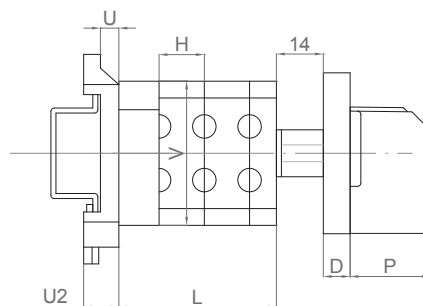
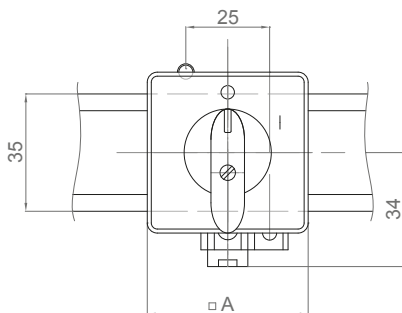

**S63, 100, 160 JLD**

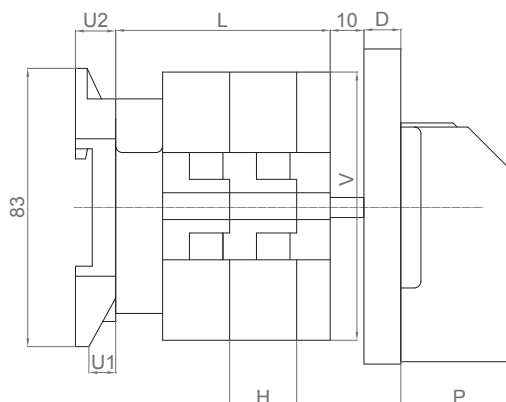
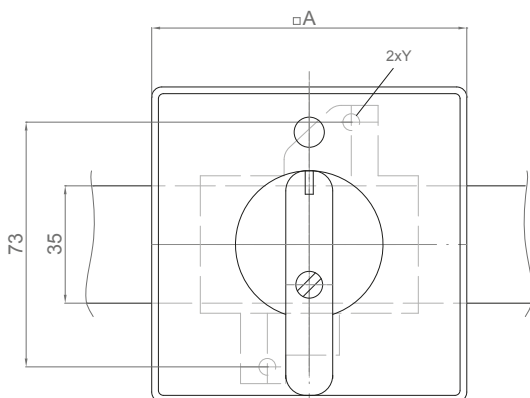

# CAM SWITCHES S ... JBD

- Switch with rear fixing of the control element with frontal plate in the door
- Execution JB only with lever, without frontal plate
- possibility to deliver also shaft of different length - dimension T according to customer's requirements



S 6,10 JBD

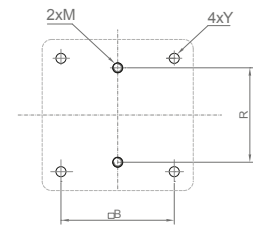
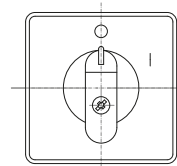
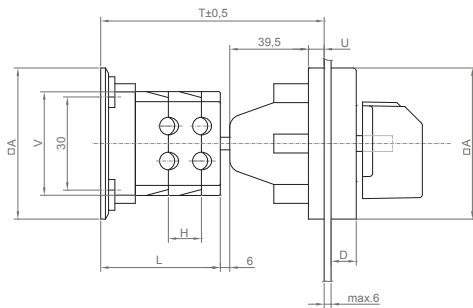

S 16, 25, 32, 40, 63 JBD

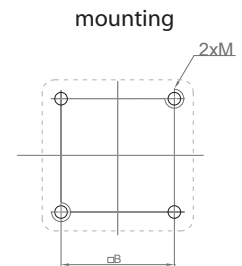
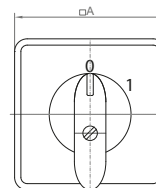
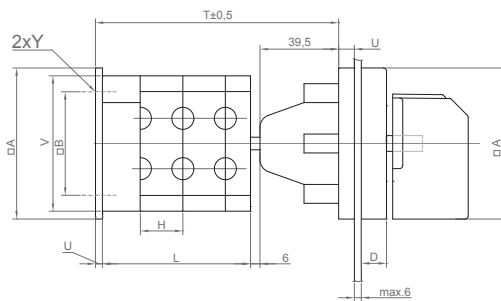

S 100, 160 JBD

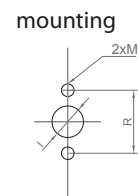
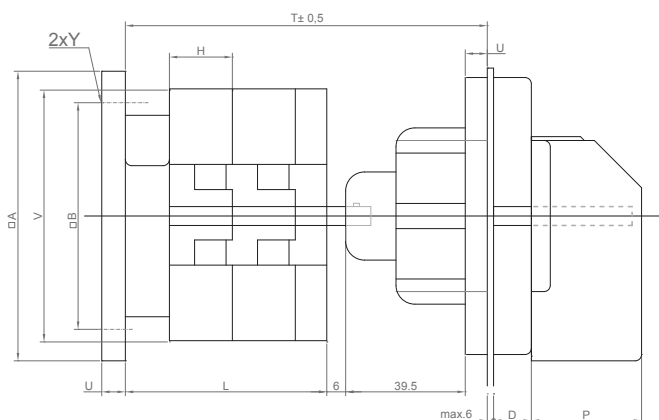

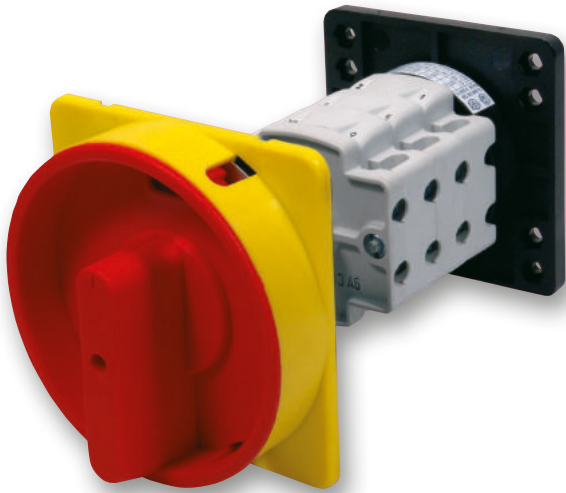

## CAM SWITCHES S ... JBU

- Switch with rear fixing of the control element with lockable lever in the door
- Execution JBU only with lever, without a lock
- possibility to deliver also shaft of different length - dimension T according to customer's requirements

S 6,10 JBU

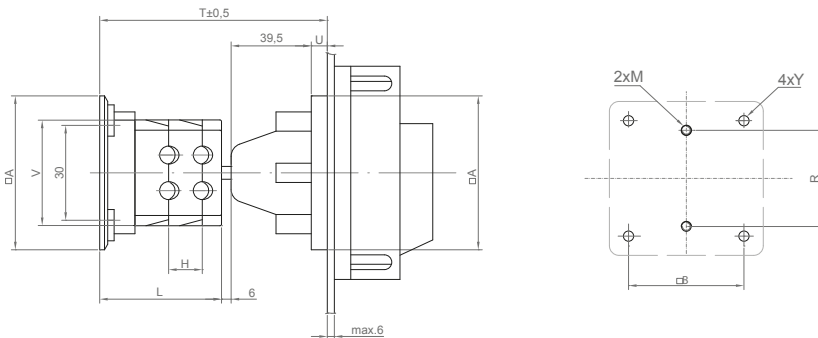

S 16, 25, 32, 40, 63 JBU

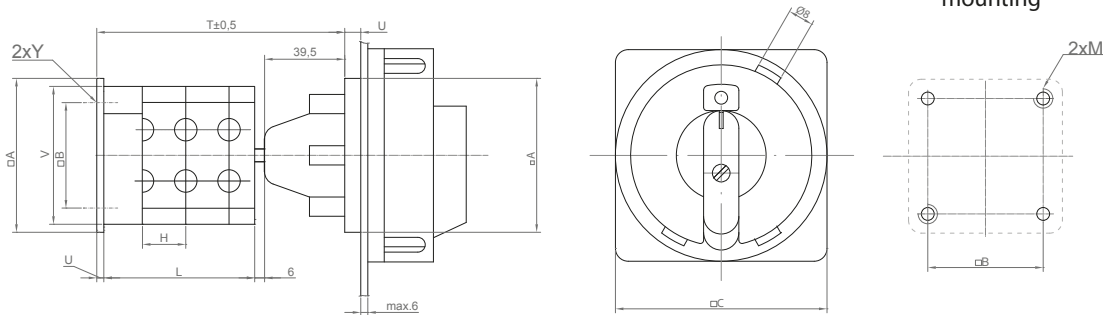

S 100, 160 JBU

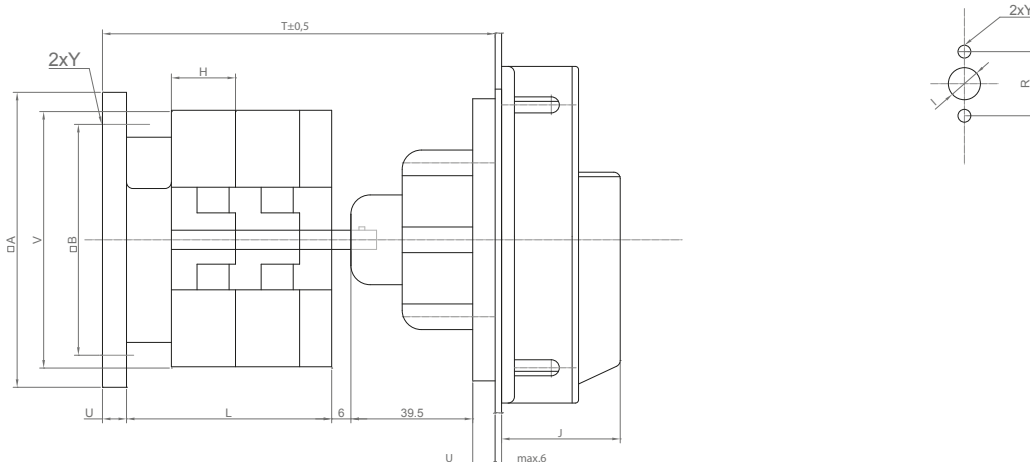



## CAM SWITCHES S ... JBZ

- Switch with rear fixing of the control element with propelling lock in the door with lock in „O“ position (other position cite)
- Execution JB only with lever, without a lock
- possibility to deliver also shaft of different length - dimension T according to customer's requirements

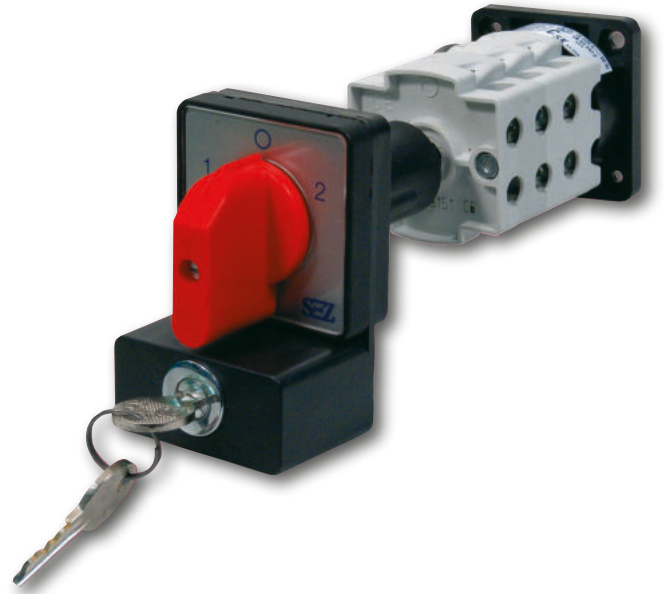

S 6,10 JBZ

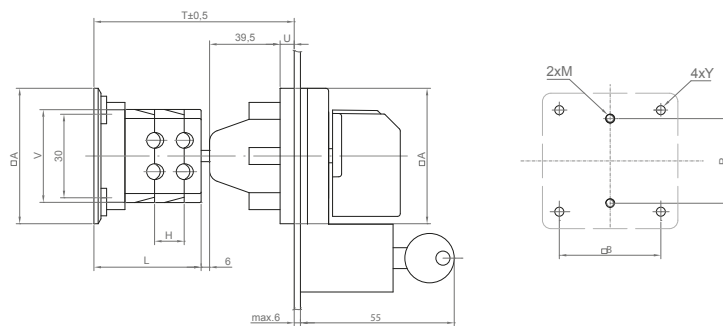

S 16, 25, 32, 40, 63 JBZ

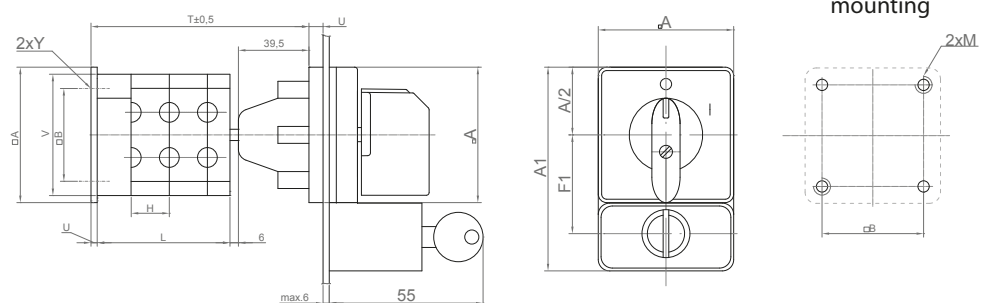

S 100, 160 JBZ

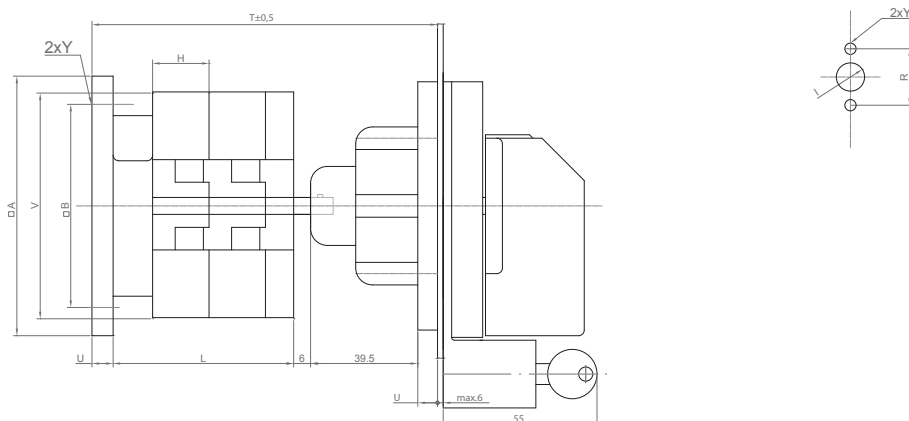



## CAM SWITCHES S ... JP

- switch in plastic enclosure - IP65
- fixing with two screws M4 with washers (S6, 10, 16,25) or M5 for S32, 40,63 and 100
- Supplied including 2 cable glands:
  - Pg 16 - for S6J - S16J
  - Pg 21 - for S25J - S40J
  - Pg 29 - for S63J and S100J

S 6, 10, 16, 25, 32, 40, 63, 100 JP

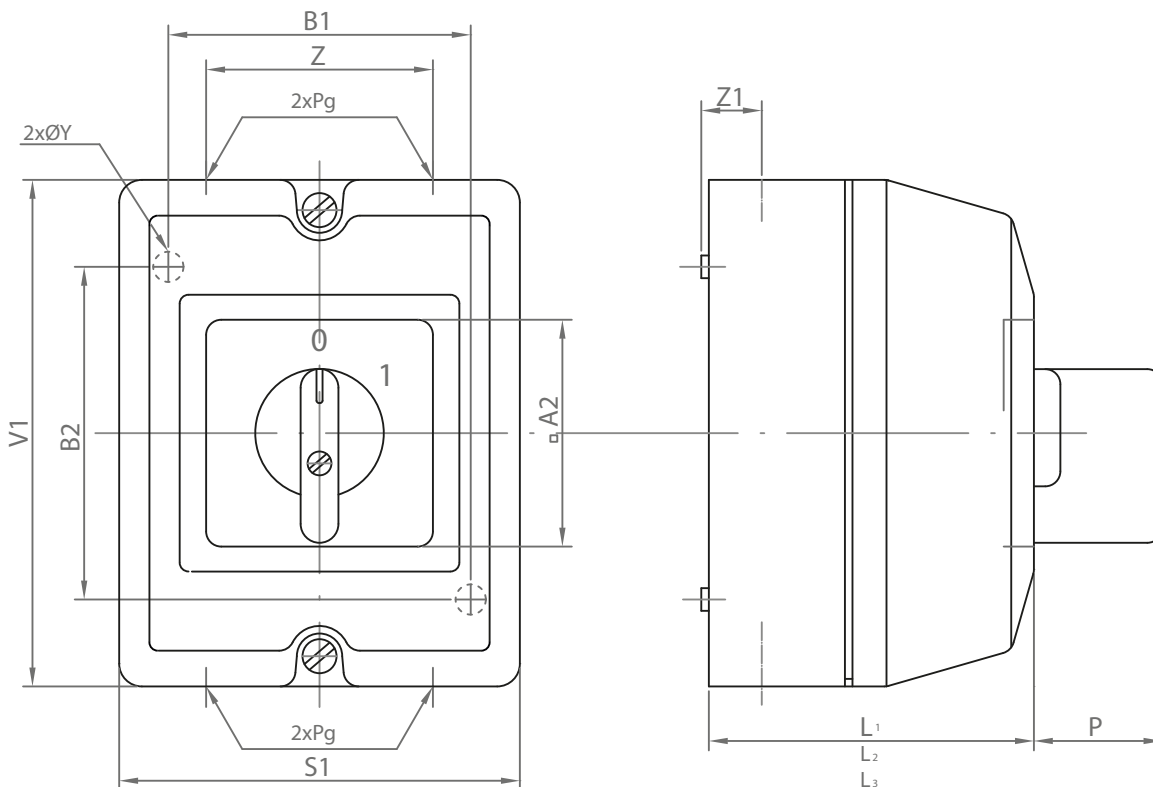

## CAM SWITCHES S ... JPU

- Switch in the plastic enclosure with lockable handle with 3 padlock - IP65
- Switch with propelling lock - designation S ... JPZ - switch with frontal plate with propelling lock - designation S ... JZ
- fixing with two screws M4 with washers (S6, 10, 16,25) or M5 for S32, 40,63 and 100
- Supplied including 2 cable glands:  
Pg 16 - for S6J - S16J  
Pg 21 - for S25J - S40J  
Pg 29 - for S63J and S100J



S 6, 10, 16, 25, 32, 40, 63, 100 JPU

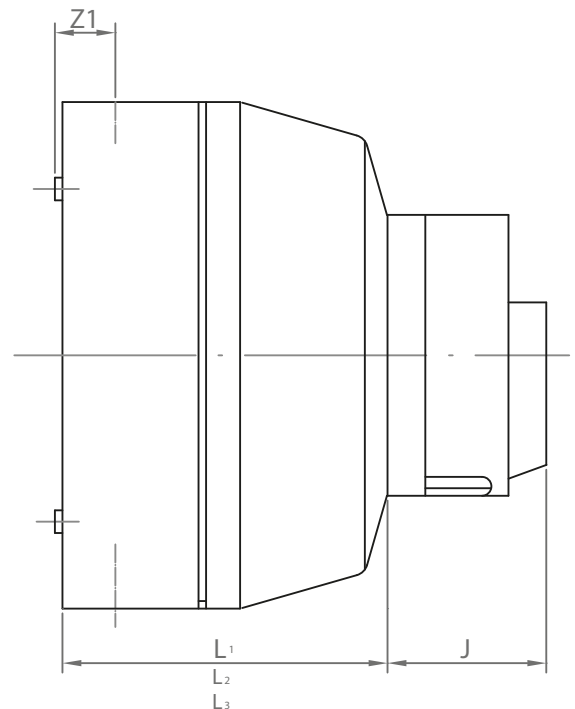
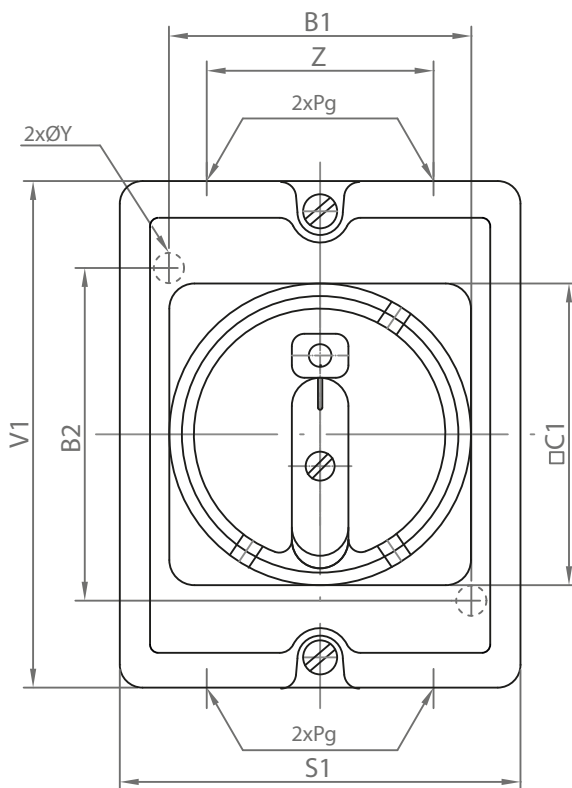



## CAM SWITCHES S ... JPD

- Switch in the plastic enclosure with frontal plate - IP65
- fixing with two screws M4 with washers (S6, 10, 16,25) or M5 for S32, 40,63 and 100
- Supplied including 2 cable glands:  
Pg 16 - for S6J - S16J  
Pg 21 - for S25J - S40J  
Pg 29 - for S63J and S100J

S 6, 10, 16, 25, 32, 40, 63, 100 JPD

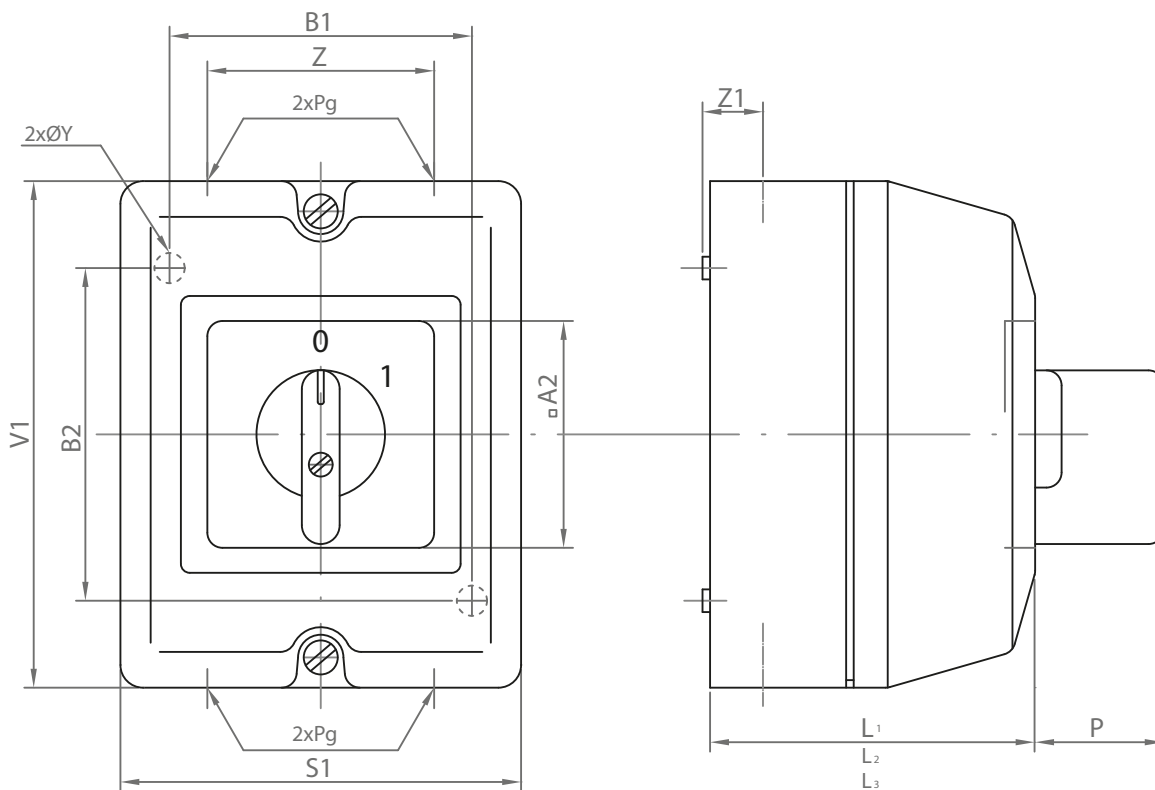

S 6 - 25 JPU



S 32 - 63 JPU



S 32 - 63 - 100 JPU



S 6 - 25 JPZ



S 32 - 63 JPZ



S 32 - 63 - 100 JPZ



S 6 - 25 JPD, JP



S 32 - 63 JPD, JP



S 32 - 63 - 100 JPD, JP



## S 160 JPD



## CAM SWITCHES S 160 JPD, JPU, JPZ

- switch in enclosure from plastic material with the frontal plate (JPD) and lever lockable with 3 padlocks (JPU), with lamella propelling lock (JPZ) - IP 54
- switches up to 3 chambers are in the case JP (dimensions 280 x 160 x 165 mm)
- switches with four and more chambers are in the case VMS 32 (dimensions 320 x 220 x 180 mm, the case height may be enlarged at need adding the modules with the height 75 mm)
- 2 cable glands Pg 36 are included

## S 160 JPU



### Enclosure type JP

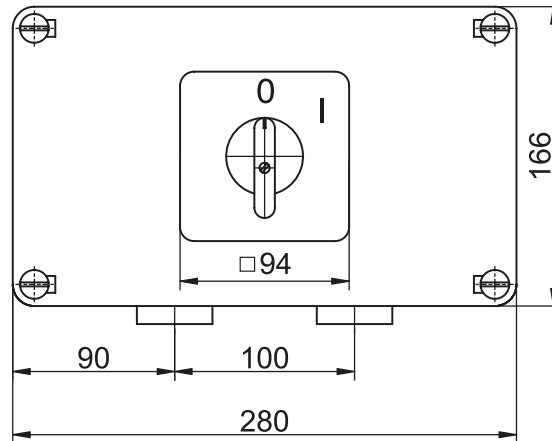

### Enclosure type VMS 32

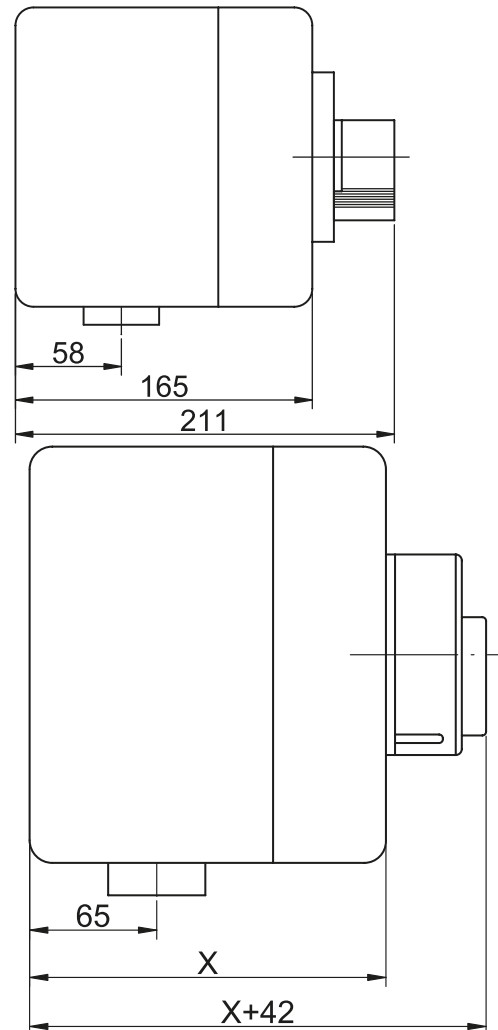
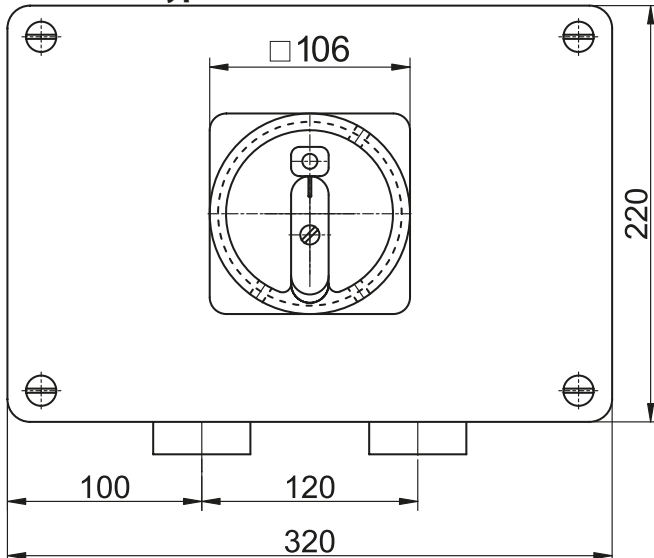

X = 180; 255; 330; ...

# CAM SWITCHES S 16, 25 NJ, NJU, NJZ, NJD

- switch in enclosure from plastic material in combination with 3 fuses (E 27) and terminals to connect the zero and protection conductor - IP 54
- S ... NJ – with lever
- S ... NJU – with lever and locking by 3 padlocks
- S ... NJZ – with lever and locking by lamella propelling lock
- S ... NJD – with lever and front panel
- scaled sealing rubber terminals

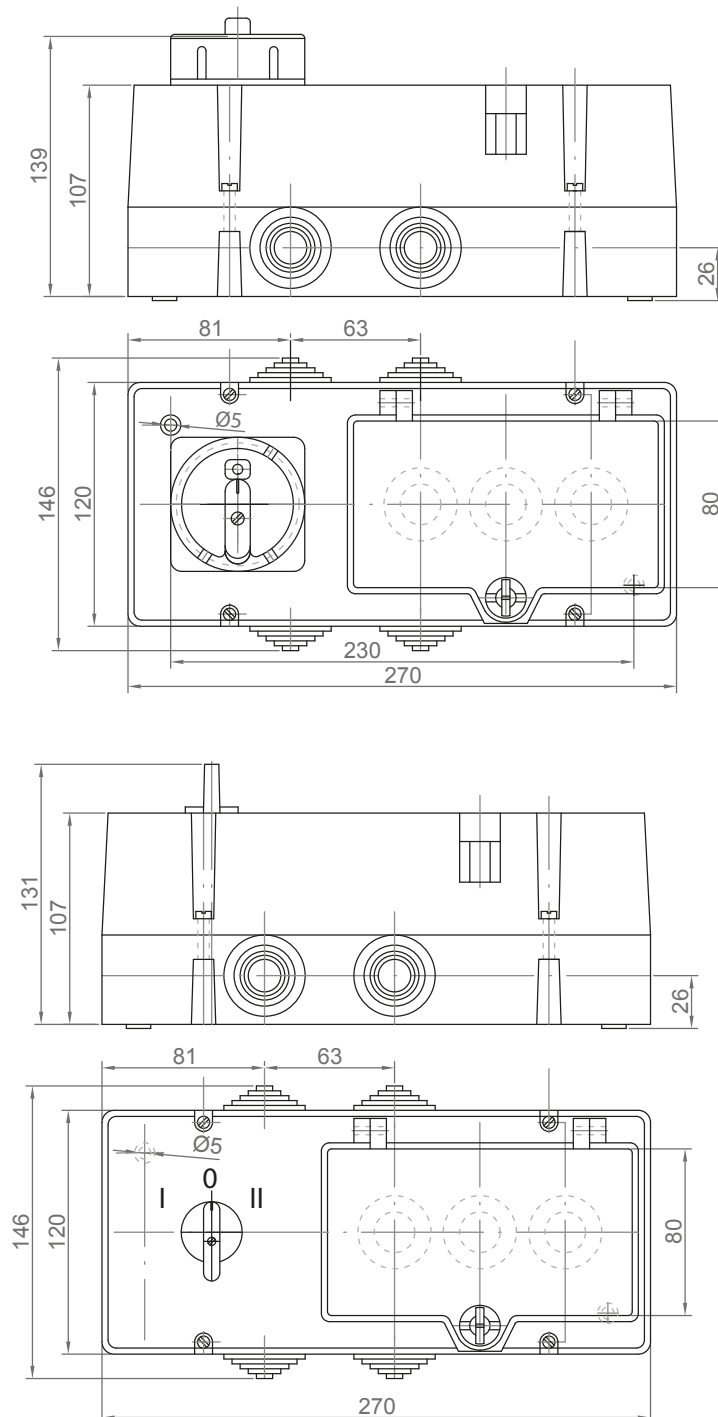



## CAM SWITCHES S ... JA, JAZ

- switches in Al enclosure, IP 54
- S ... JA – with lever
- S ... JAZ – with lever and locking lamella propelling lock

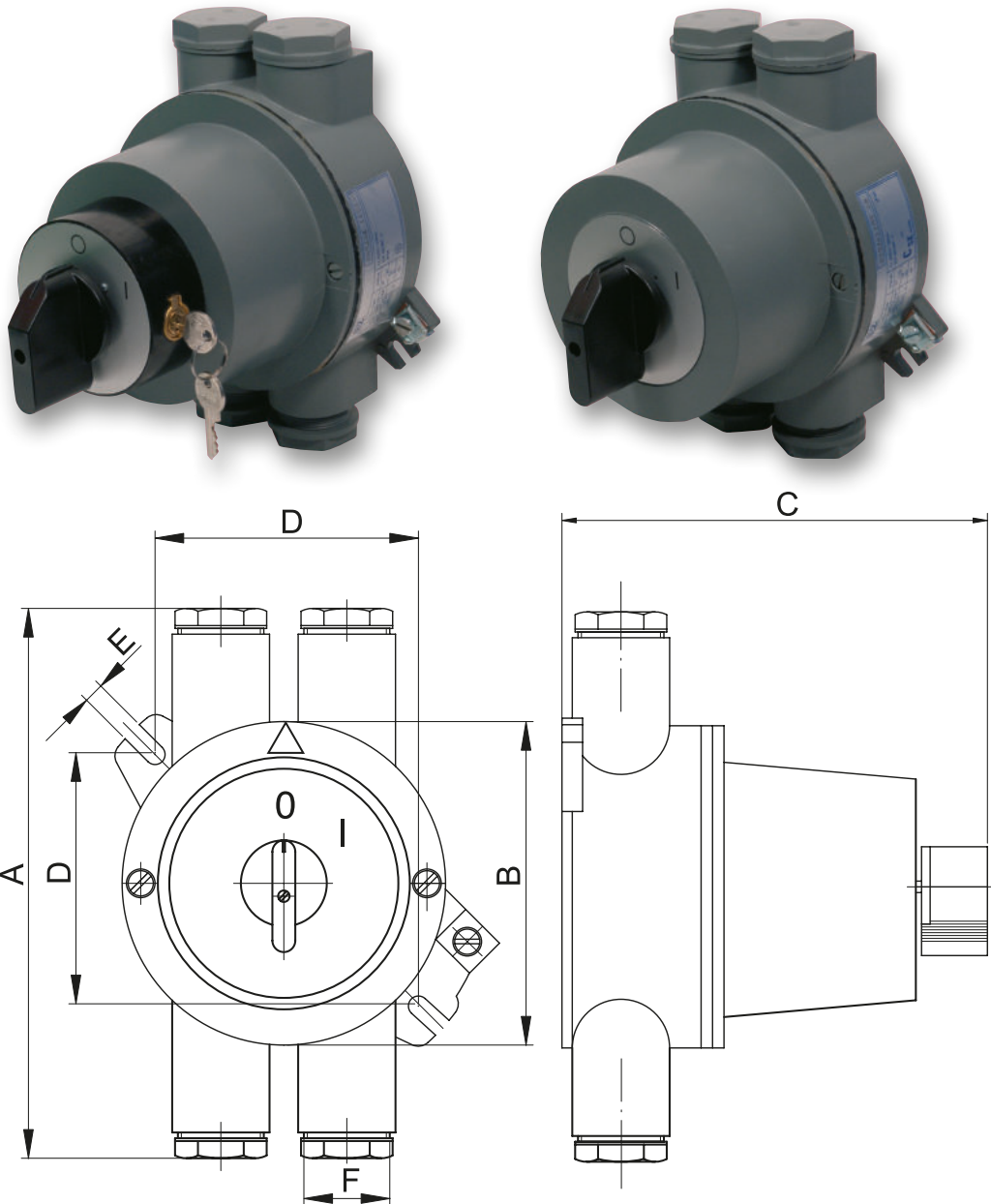

Type	Version	A	B	C	D	E	F
S 16, 25 JA	1103, 9151, 9551, 9552, 2203	190	Ø 113	134	90	7	P21
	9153			167			
S 16, 25 JAZ	1103, 9151, 9551, 9552, 2203	190	Ø 113	168	90	7	P21
	9153			201			
S 32, 63 JA	1103, 9151, 2203	235	Ø 113	166	122	9	P29
	9551, 9153, 9552			198			
S 32, 63 JAZ	1103, 9151, 2203	235	Ø 113	200	122	9	P29
	9551, 9153, 9552			232			



## CAM SWITCHES S ... JI, JIZ

- switches in Al case in combination with 3 fuses (E 27,E 33), IP 54
- S ... JI – with lever
- S ... JIZ – with lever and locking with lamella propelling lock



S 16, 25, 32, 40, 63 JI, JIZ

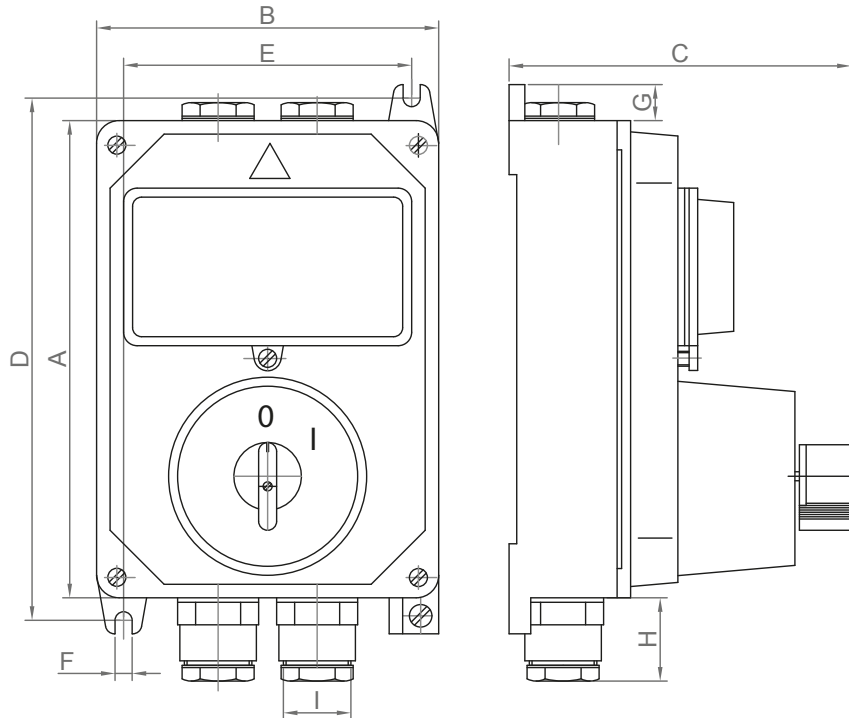

Type	Version	A	B	C	D	E	F	G	H	I
S 16, 25 JI	1103, 9151, 9551, 9552, 2203	212	152	136	226	125	7	16	34	P21
	9153			168						
S 16, 25 JIZ	1103, 9151, 9551, 9552, 2203			170						
	9153			202						
S 32, 63 JI	1103, 9151, 2203	269	212	166	300	180	9	25	39	P29
	9551, 9153, 9552			198						
	S 32, 63 JIZ			1103, 9151, 2203						
9551, 9153, 9552				253						

## OTHER DIAGRAMS - SEE PAGES D37 - D47

### Polarity reversing switch (Dahlander)

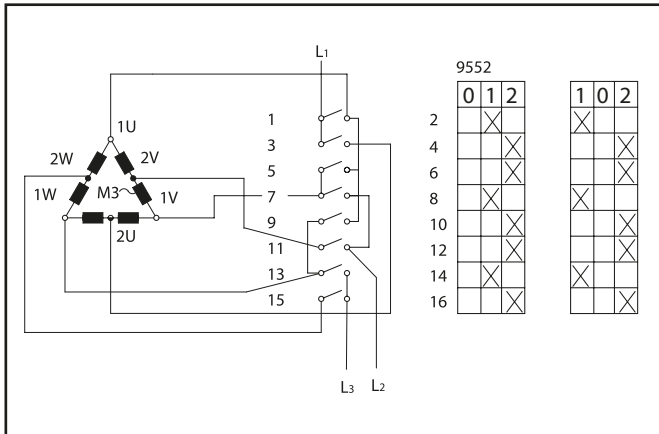

### Reversible changeover switch Y-D

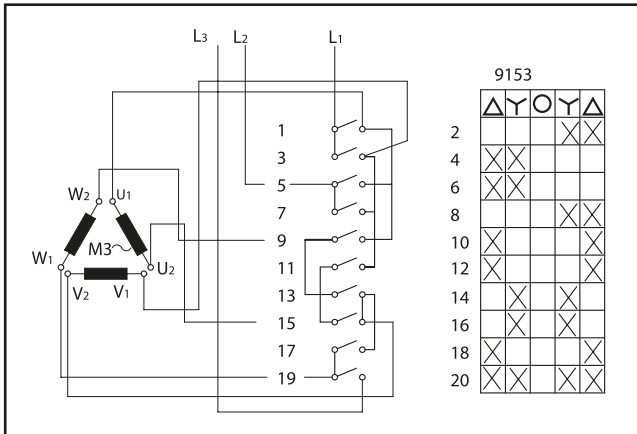

### Switch Y-D

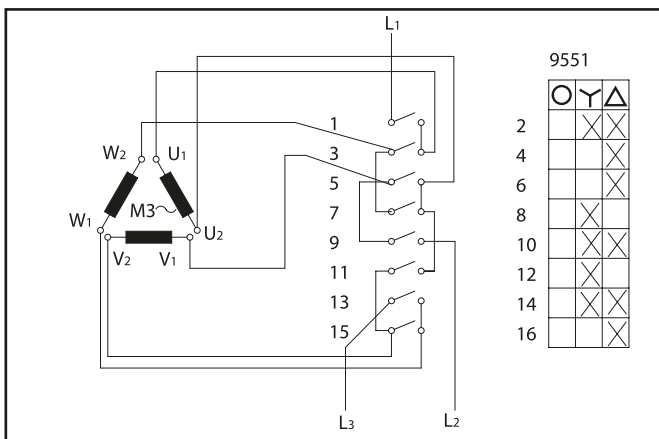

### Reversible switch

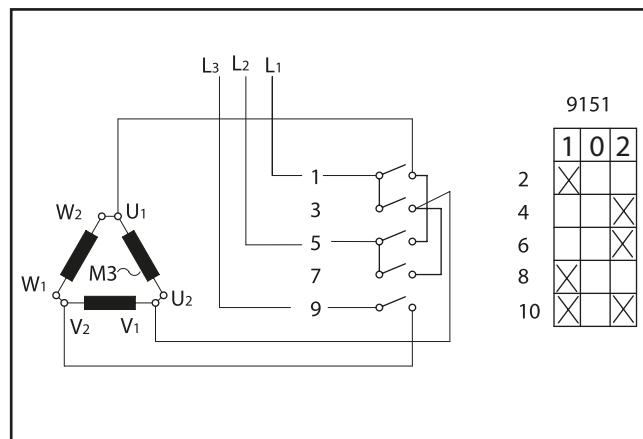

### Network switch

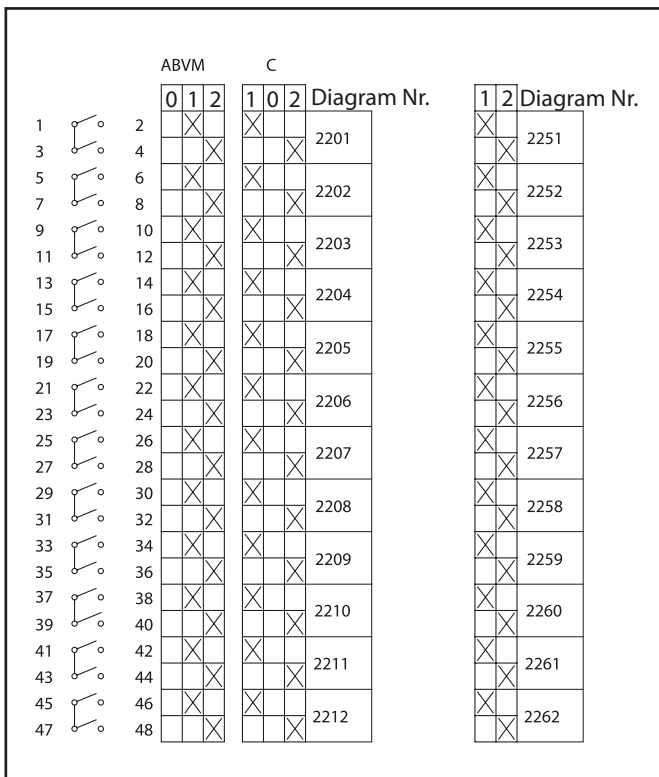

### Pole breaker

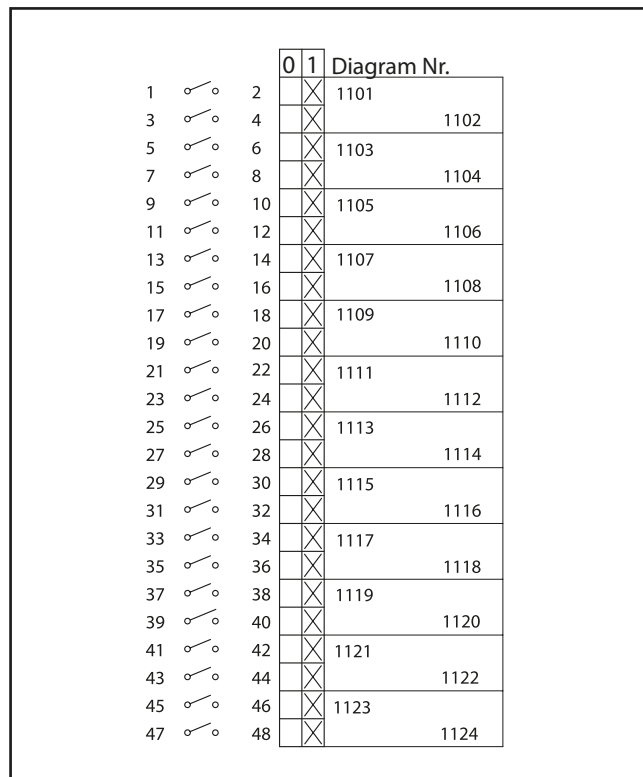

	01	02	03	04	05	06	07	08	09	
60°										
10										
20										
30										
40										
50										
90°	60	61	62	63	64	65	66	67	68	
69	70	71	72	73	74	75	76	77	78	
79	80	81	82	83						

	90	91	92	93	94	95	96	97	98
30°									
99	100	101	102	103	104	105	106	107	108
109	110	111	112	113	114	115	116	117	118
119	120	121	122	123	124	125	126	127	128
129	130	131	132	133	134	135	136	137	138
139	140	141	142	143	144	145			
151	152	153	154	155	156	157	158	159	
45°									
160	161	162	163	164	165	166	167	168	169
170	171	172	173	174	175	176	177	178	179
180	181	182	183	184	185	186	187	188	

## Label designations

1

**HLAVNÝ VYPÍNAČ**  
otvárat' v polohe 0

2

HAUPTSCHLATER      MAINSWITSCH  
  
ÖFFEN IN              OPEN  
0 - STELLUNG        0 - POSITION

3

**WATTMETER**

4

**VOLTMETER**

5

**AMPERMETER**

6

**VOLTMETER  
AMPERMETER**

7

**OHREV**

8

**ČERPADO**

9

**MOTOR**

10

**POSUV**

11

ОСНОВНОЙ ВЫКЛЮЧАТЕЛЬ  
ОТКРЫВАТЬ В СОСТОЯНИИ 0

12



- Another text on labels please state in your order

# SEZ Krompachy a.s.

Hornádska ul. 1  
053 42 Krompachy

## SPECIFICATION SHEET

CAM SWITCHES	
S 6, 10, 16, 25, 32, 40, 63, 100, 160 J	
CURRENT	A
VOLTAGE	V
POWER OUTPUT	W
Application category (IEC 60 947-3)	

CUSTOMER: \_\_\_\_\_

DATE: \_\_\_\_\_ Order No.: \_\_\_\_\_

Other Requirements: \_\_\_\_\_

Switch chamber	Contact designation	Switch and reversible designation											
		1	2	3	4	5	6	7	8	9	10	11	12
1.	1 0 0 2												
2.	3 0 0 4												
3.	5 0 0 6												
4.	7 0 0 8												
5.	9 0 0 10												
6.	11 0 0 12												
7.	13 0 0 14												
8.	15 0 0 16												
9.	17 0 0 18												
10.	19 0 0 20												
11.	21 0 0 22												
12.	23 0 0 24												
	25 0 0 26												
	27 0 0 28												
	29 0 0 30												
	31 0 0 32												
	33 0 0 34												
	35 0 0 36												
	37 0 0 38												
	39 0 0 40												
	41 0 0 42												
	43 0 0 44												
	45 0 0 46												
	47 0 0 48												
—	Recommended												
-X-	Abusive												
1.													
2.													
3.													

TYPE	S	J	N
60°			
90°			
30°			
45°			

DESIGNATION	V	LS	LD	O	R	K	B	P	C	D	U	Z	G	A	I	N	F	T
REVERSIBLE DRIVE																		
FOR DIN-RAIL WITH LABEL																		
FOR DIN-RAIL WITH PANEL																		
REAR FIXING																		
CENTRAL FIXING Ø22																		
CENTRAL WITH FAB KEY																		
CONTROL THROUGH DOOR																		
PLASTIC BOX																		
WITH UNDERVOLTAGE COIL																		
PANEL + LABEL																		
THREE PADLOCKS																		
FAB PADLOCK																		
SEALING IP 65																		
IN AI COVER																		
IN AI COVER WITH FUSE																		
WITH FUSES IN PH COVER																		
LED SIGNALLING																		
WITH BUTTON																		

LEVER COLOUR	R - Red
POSITION LABEL	No.
LEVER POSITION - SWITCH ANGLE	A ↓
	B ↓
	C ↑
	D ↓
	M ↑
	V ↓
	W ↓
	Turn over 360°
	Switch angle 60°
	90°
	30°
	45°

CATALOGUE NUMBER OF ELECTRICAL SCHEME  
- PRODUCER WILL ASSIGN THE NUMBER  
IF DOES NOT EXIST.  
(Electric diagram without jumpers, marka as Diagram No. - X)

Customer will mark required electrical parameters, switching program a execution.  
Type of switchbold marked part will be set by manufacturer.

## STAGE OVER SWITCHES WITH ZERO POSITION

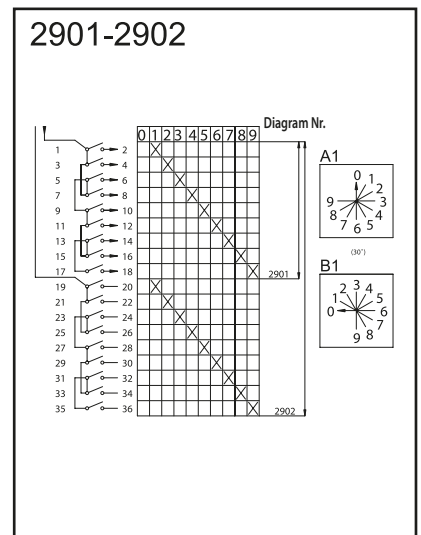
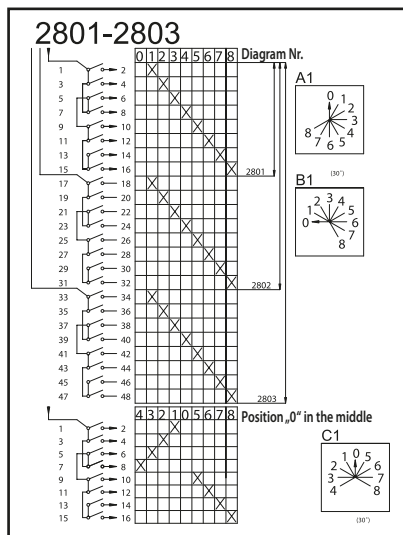
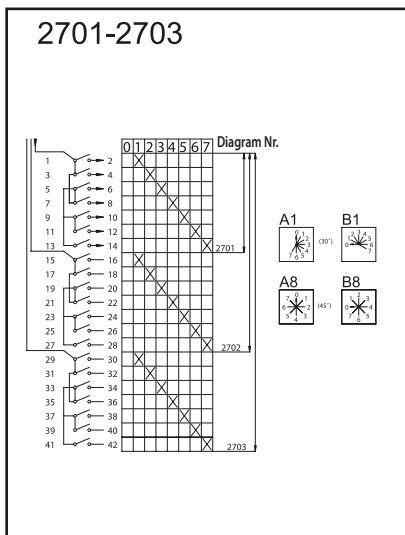
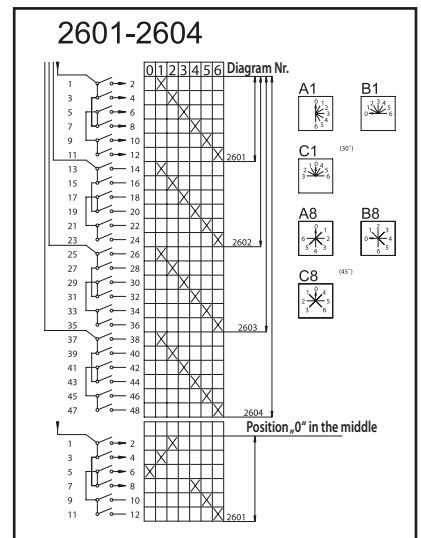
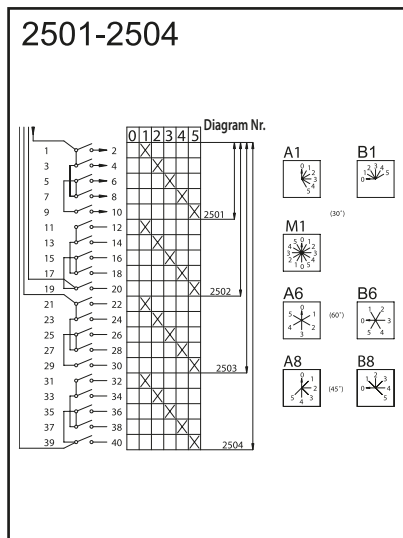
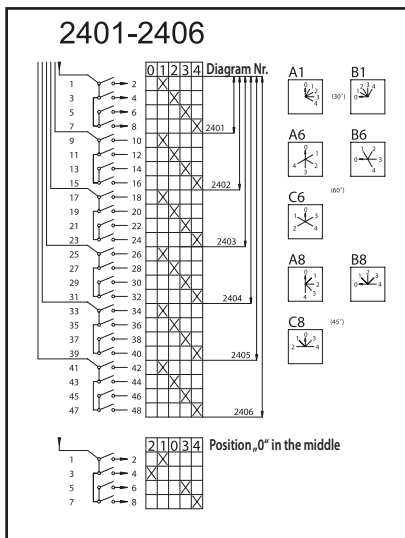
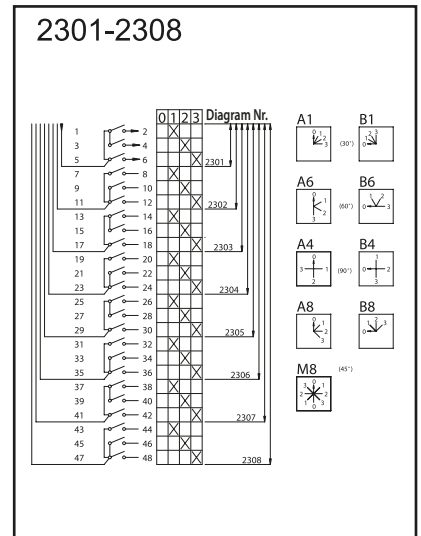
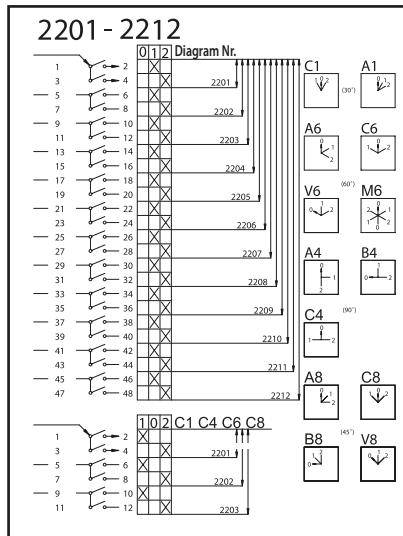
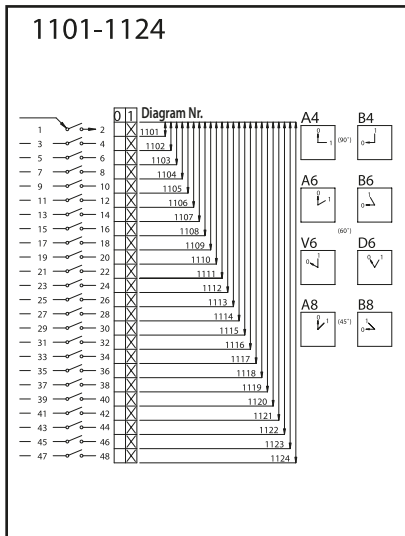

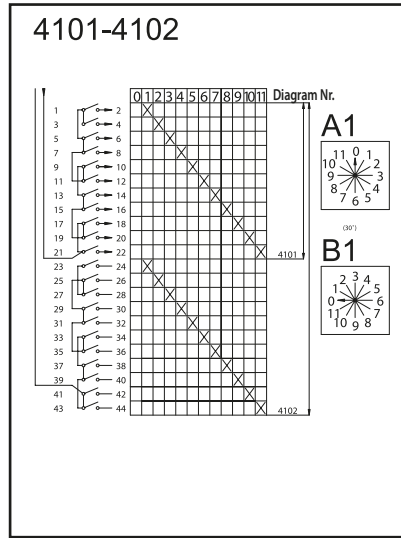
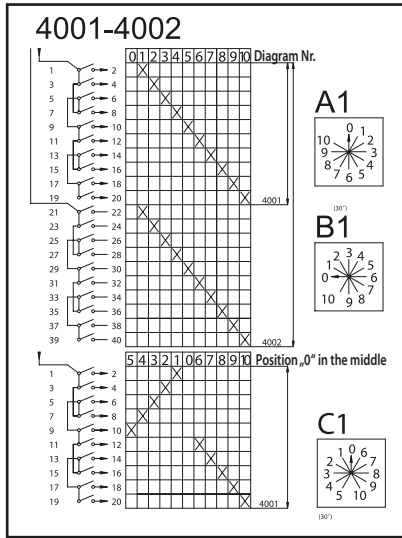

## STAGE OVER SWITCHES WITHOUT ZERO POSITION

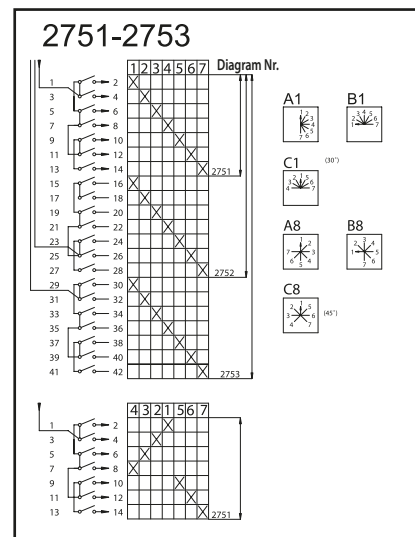
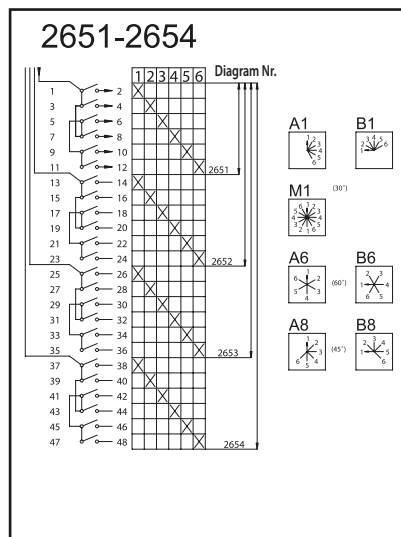
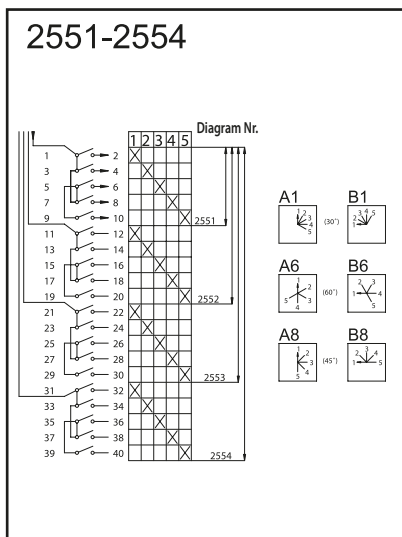
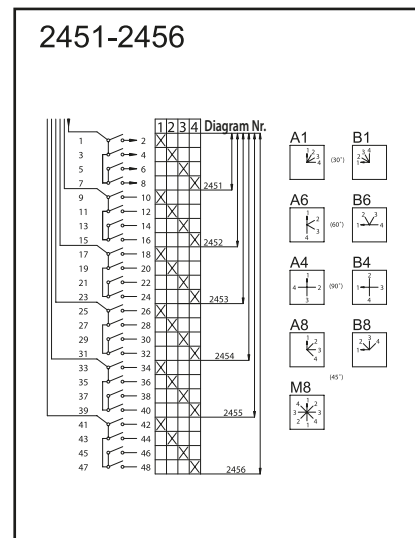
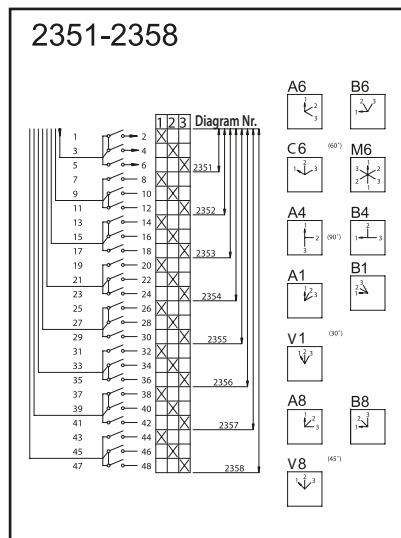
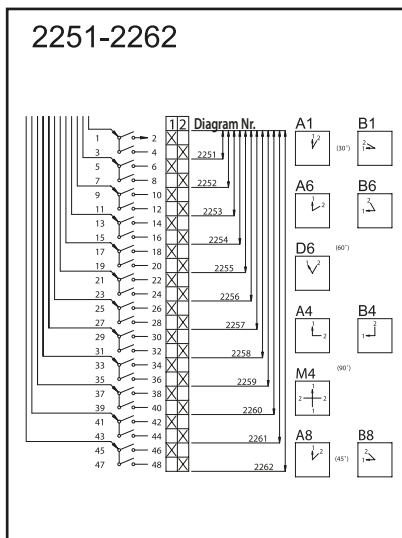



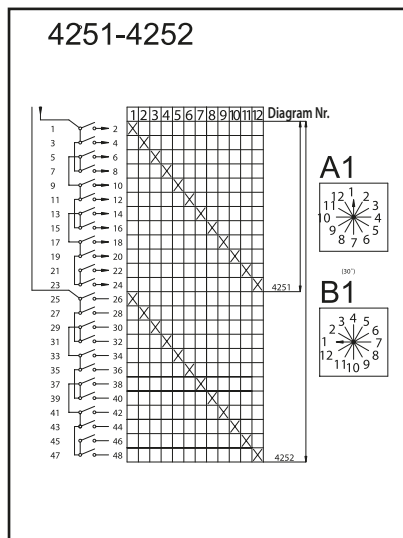
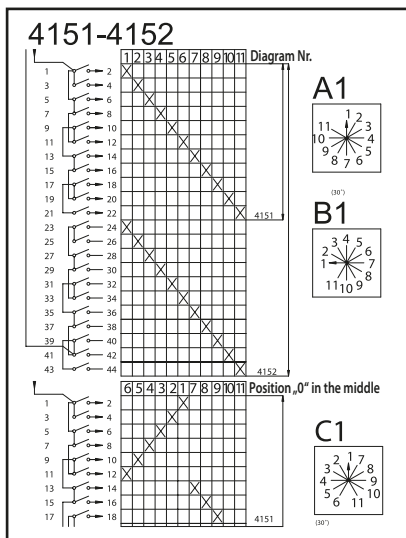
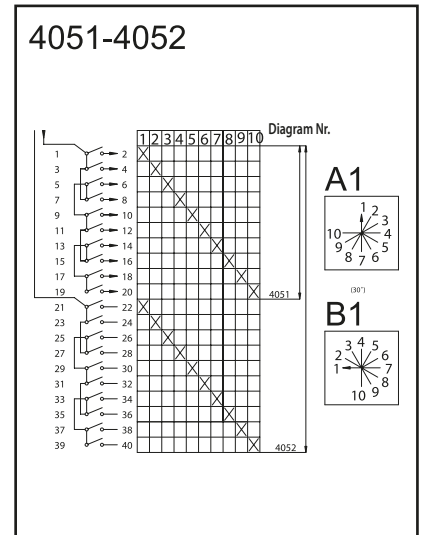
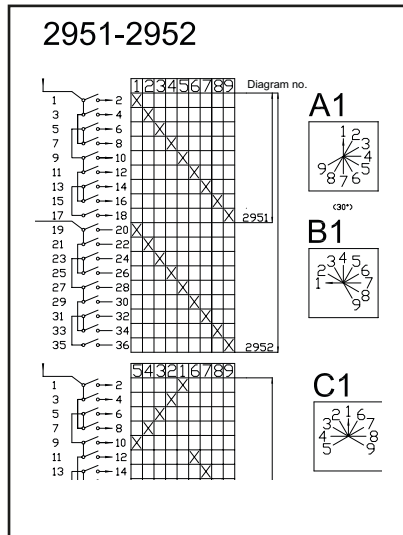
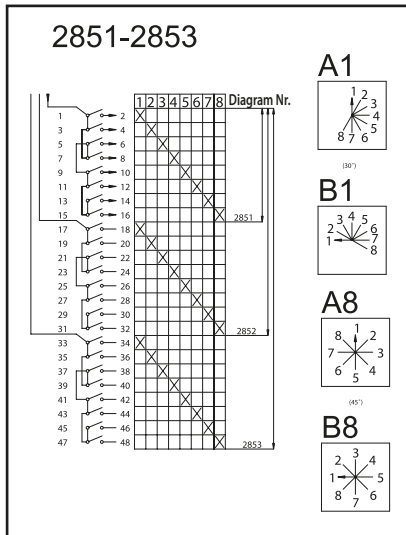

## STAGE OVER SWITCHES WITH ZERO POSITION WITHOUT BRAKE FROM POWER ON

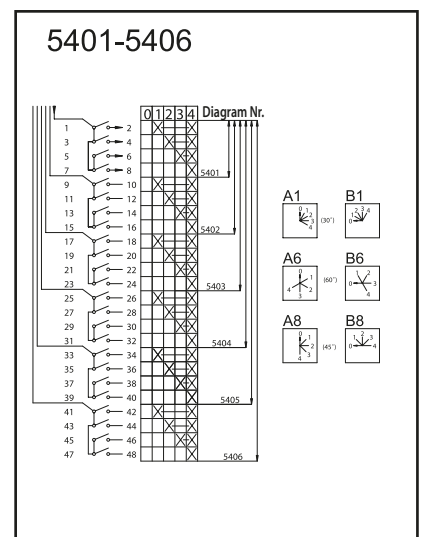
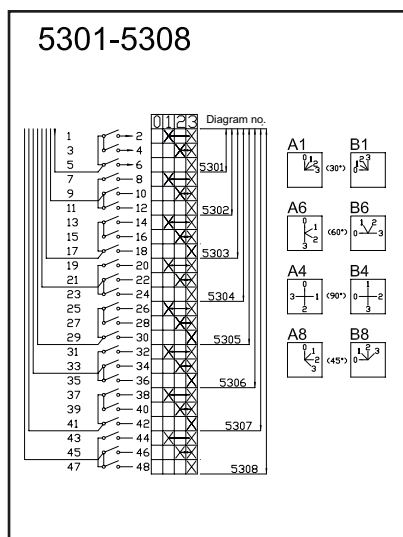
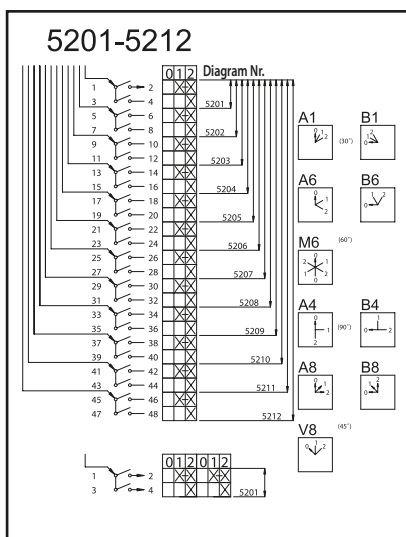

## STAGE OVER SWITCHES WITH ZERO POSITION WITHOUT BRAKE FROM POWER ON

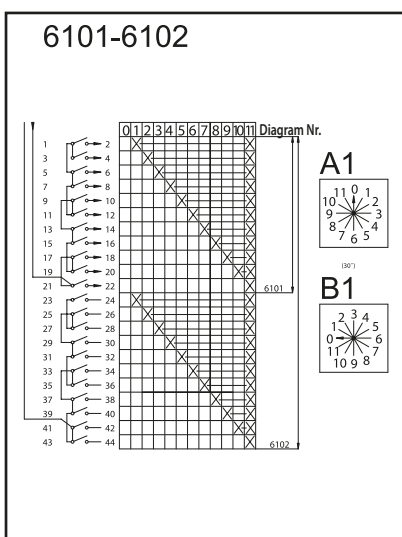
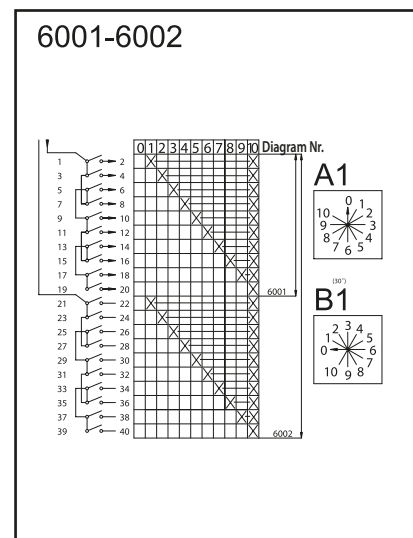
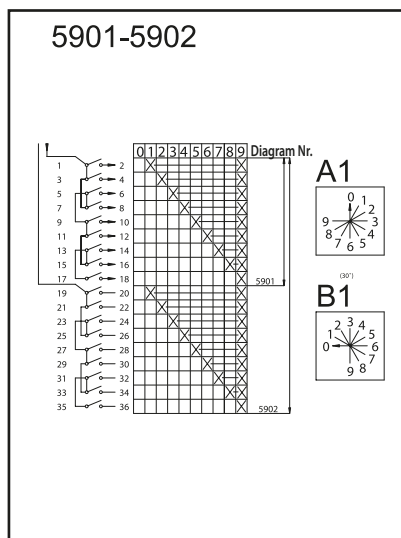
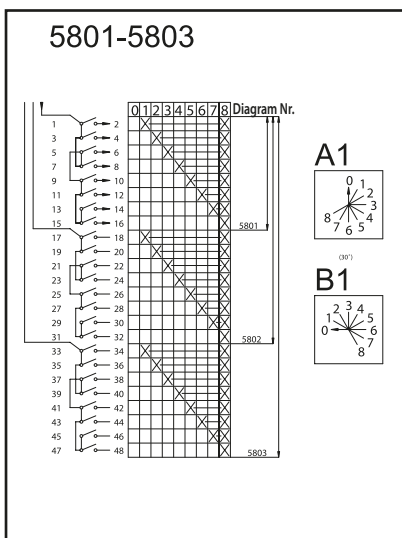
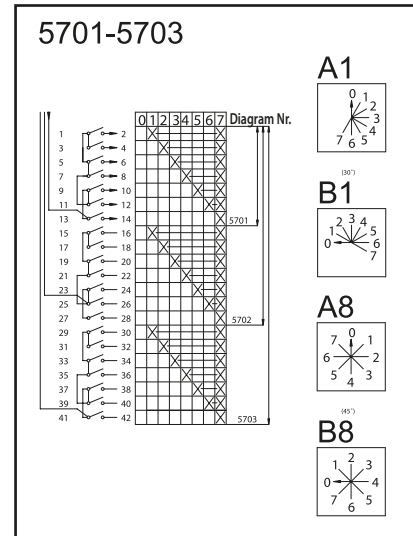
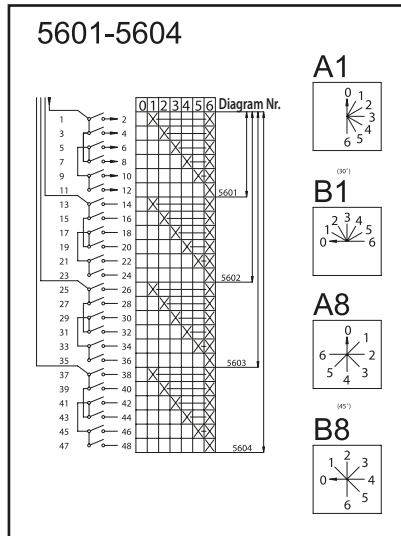
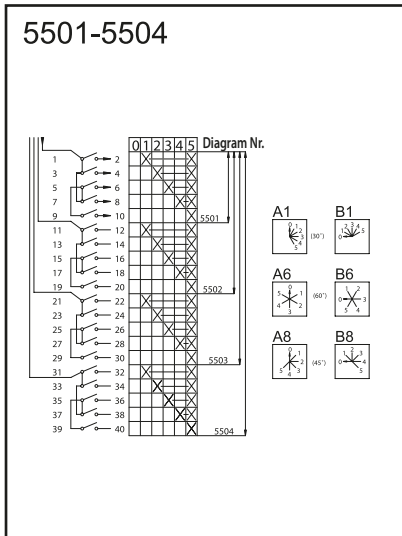

## STAGE OVER SWITCHES WITH ZERO POSITION WITH OVERLAP CONNECTIONS

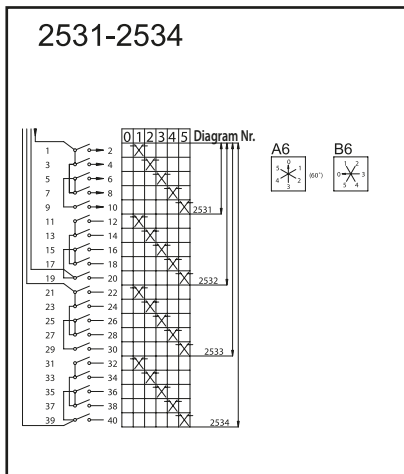
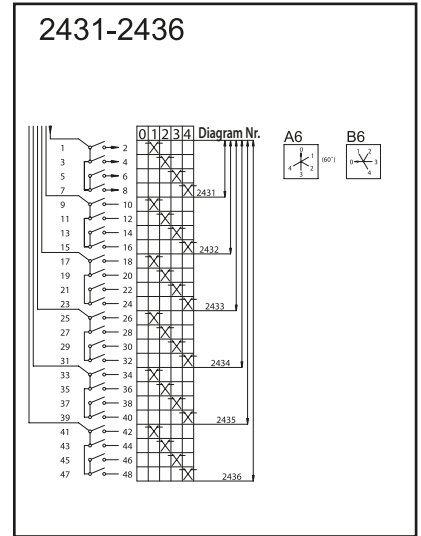
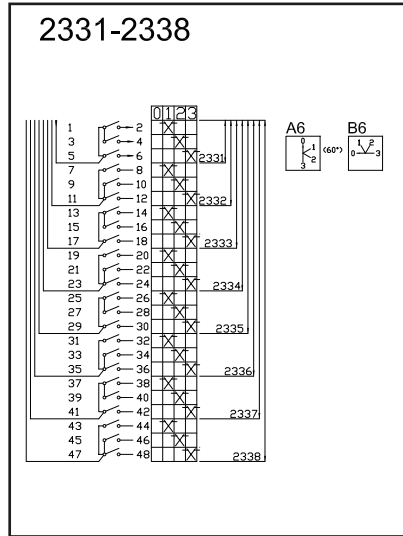
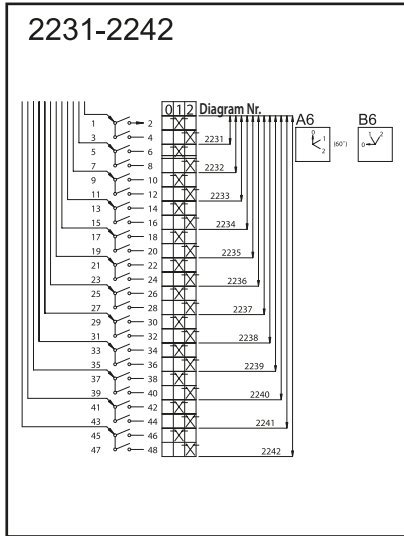

## STAGE OVER SWITCHES WITH ZERO POSITION WITHOUT OVERLAP CONNECTIONS

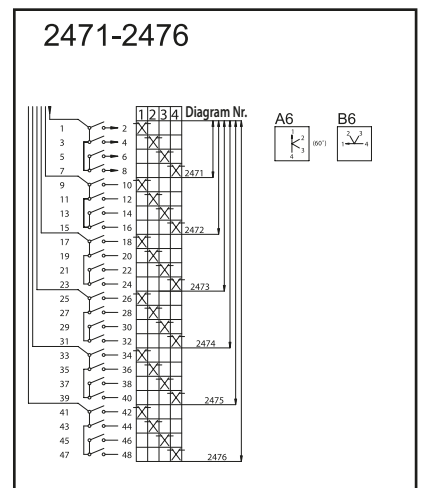
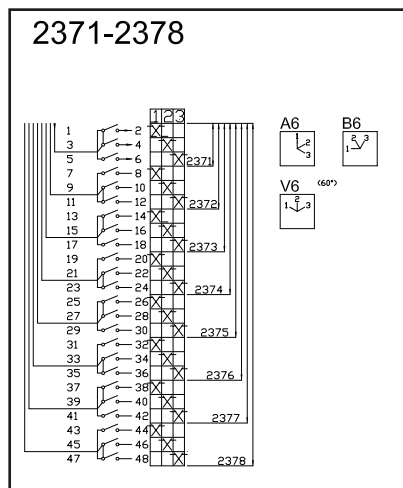
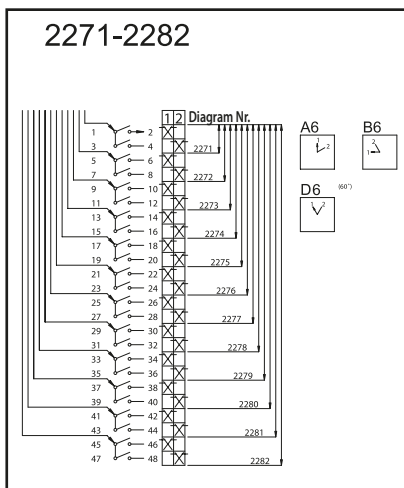

## STAGE OVER SWITCHES WITH ZERO POSITION WITH OVERLAP CONNECTIONS

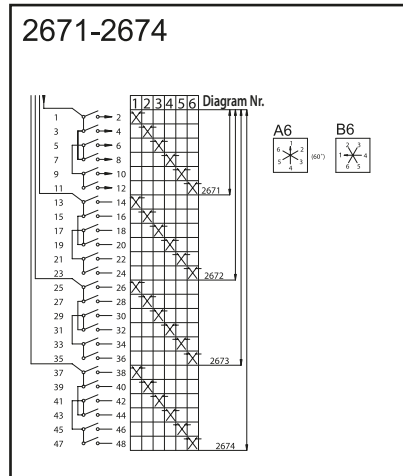
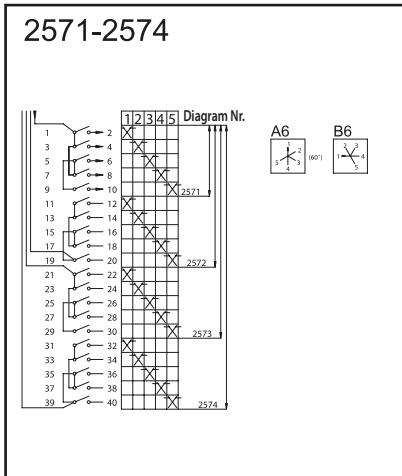

## SWITCHES FOR ORDERING RESISTANCE

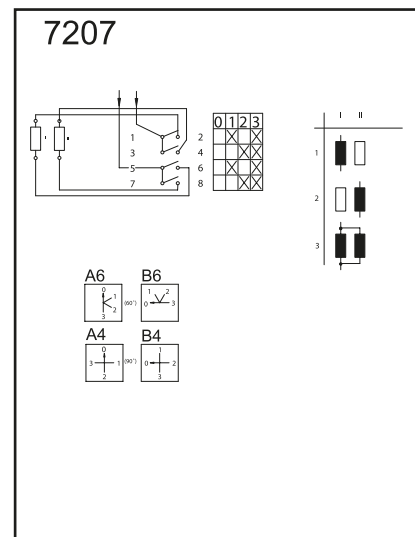
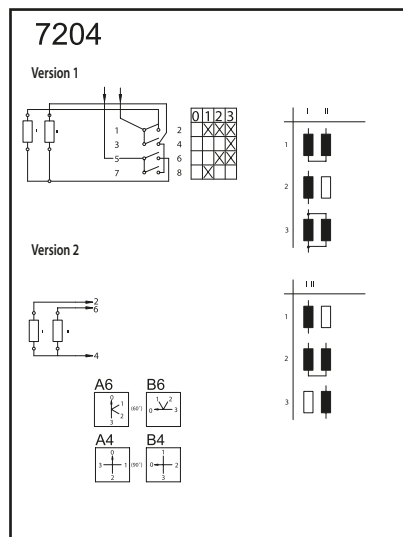
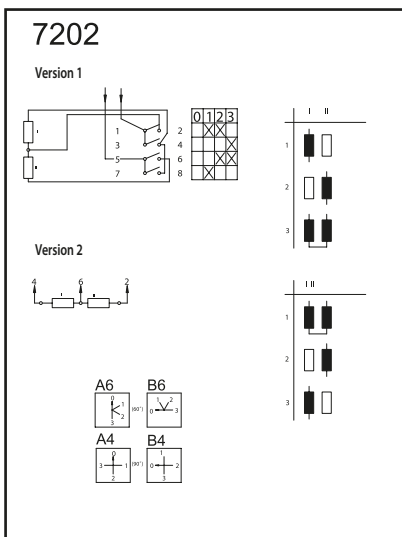
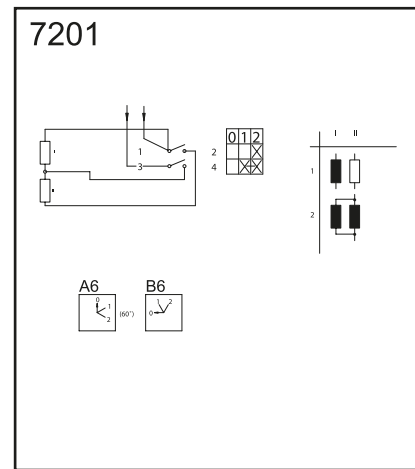
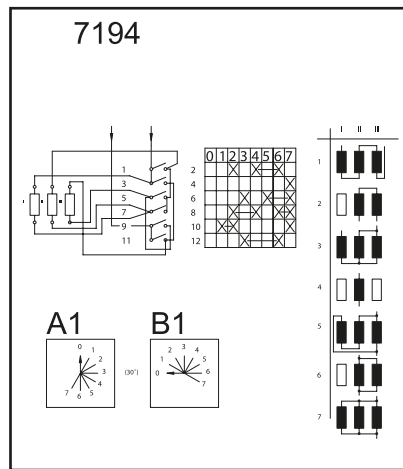
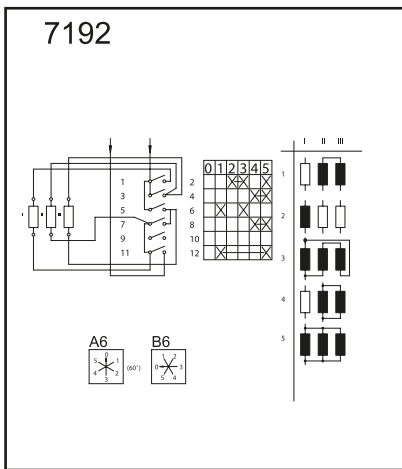

## SWITCHES FOR ORDERING RESISTANCE

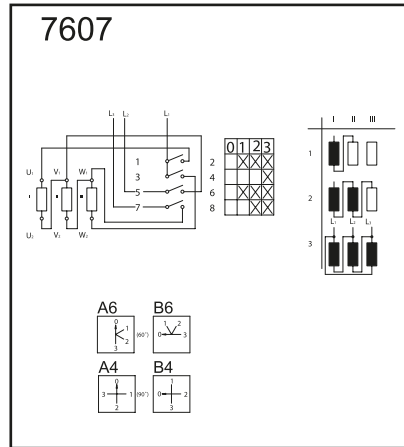
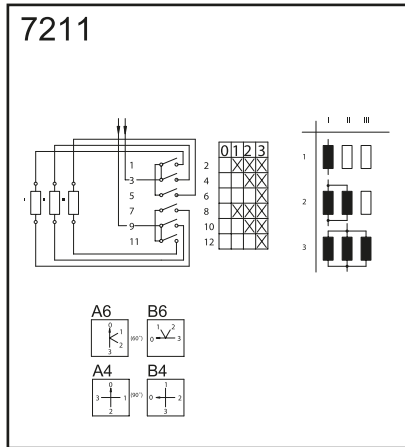

## SWITCHES FOR MEASURING INSTRUMENTS

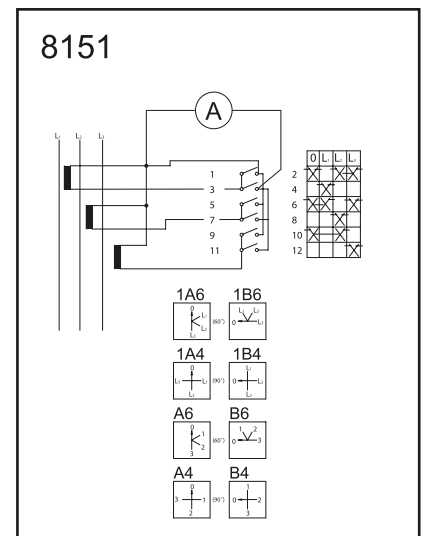
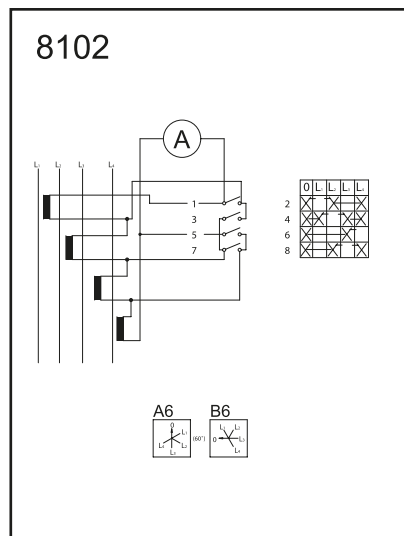
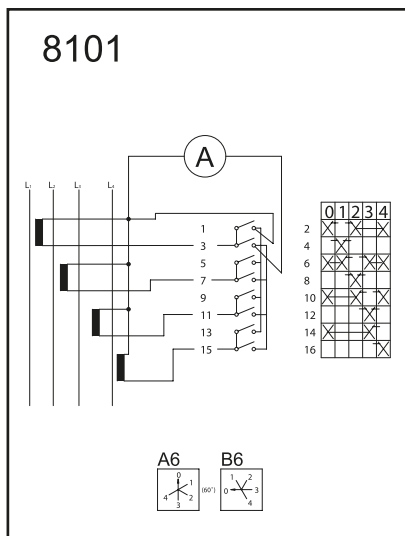
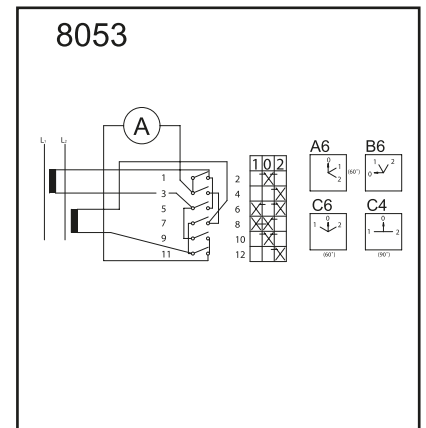
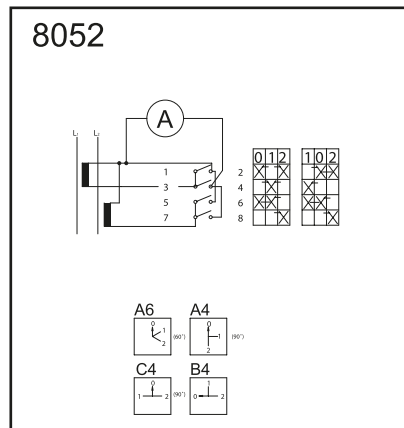
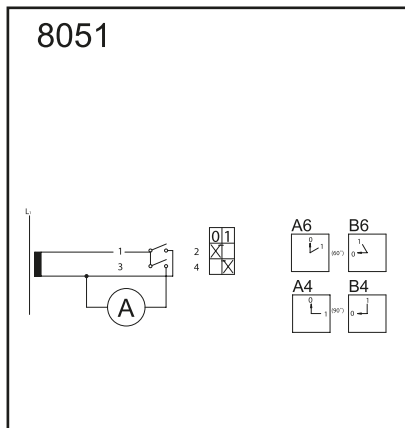

## SWITCHES FOR MEASURING INSTRUMENTS

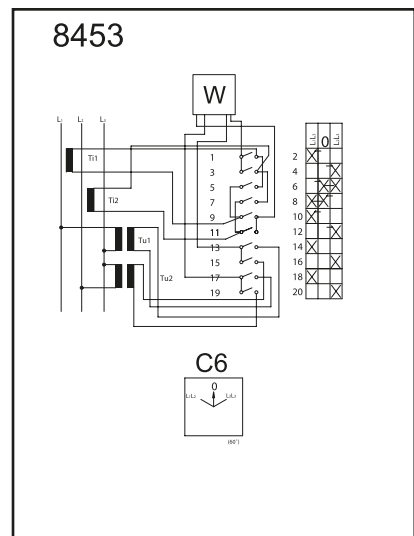
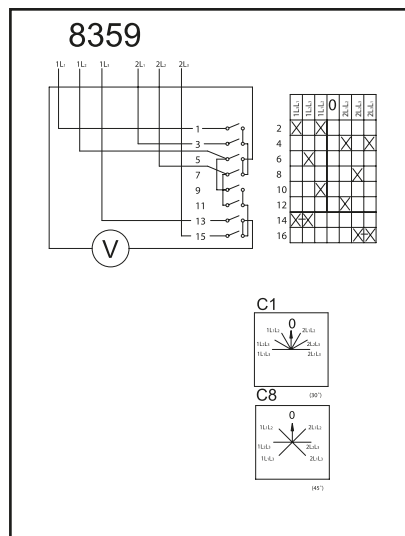
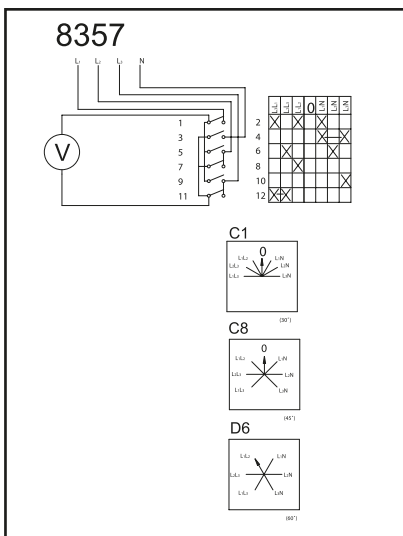
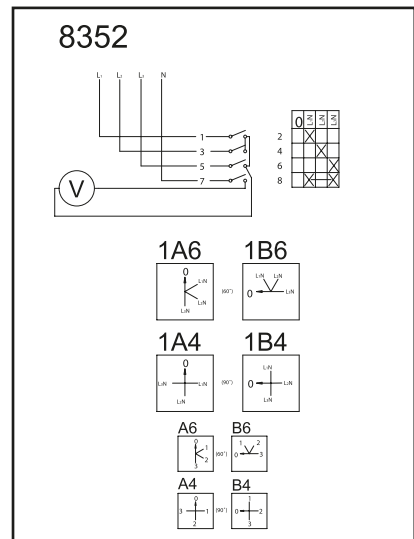
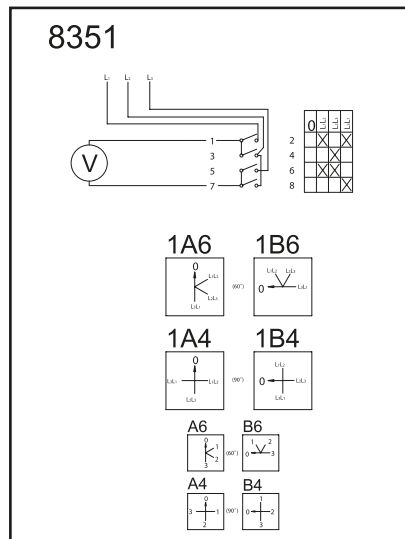
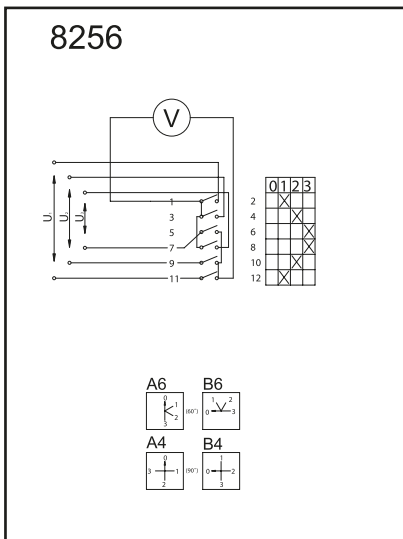
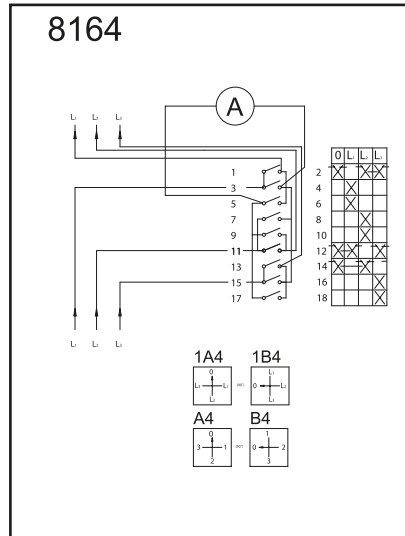
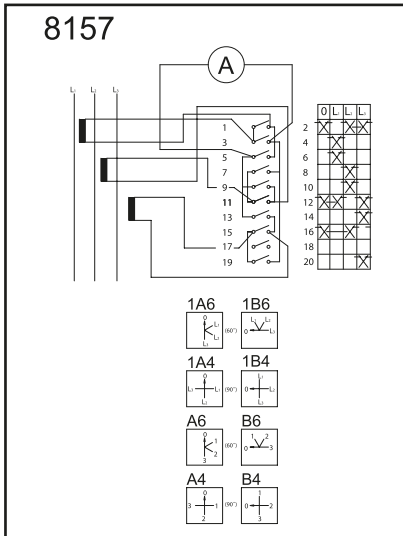

## SWITCHES FOR MEASURING INSTRUMENTS

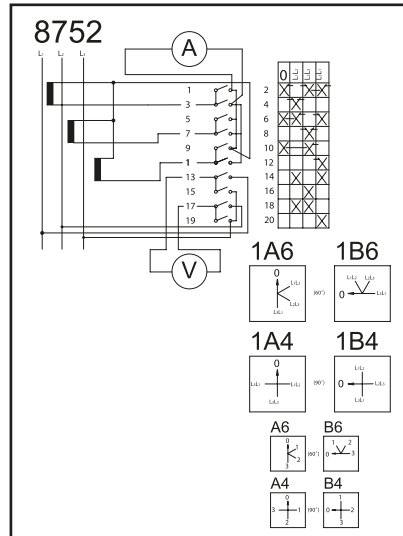
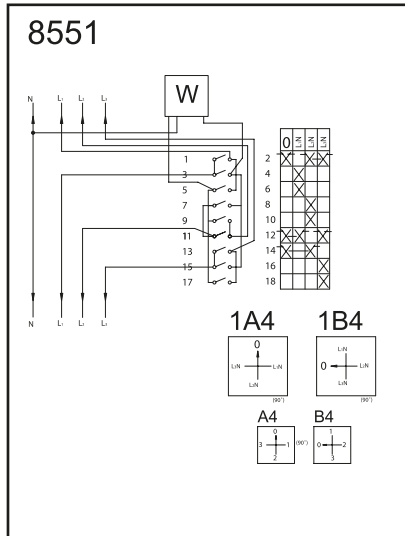

## SWITCHES FOR ONE-PHASE MOTORS

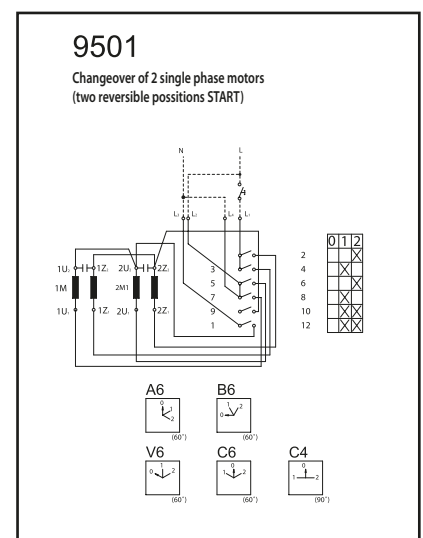
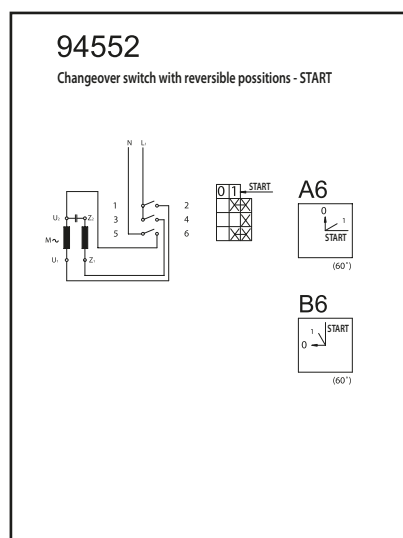
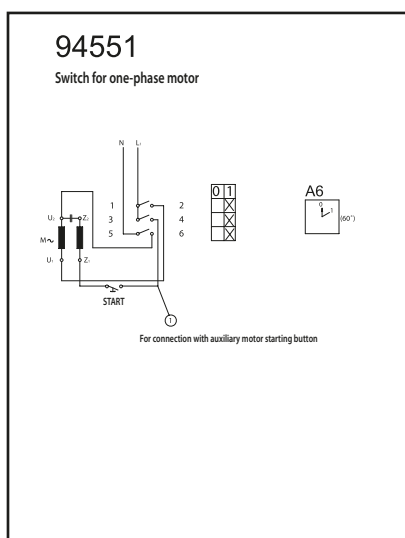
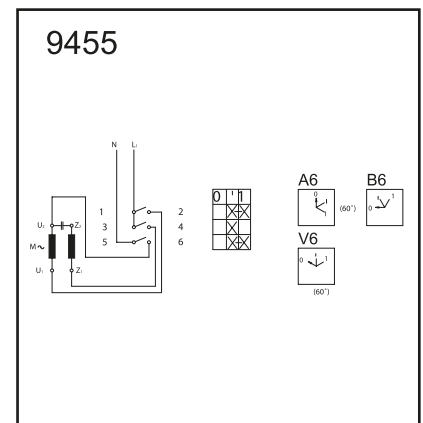
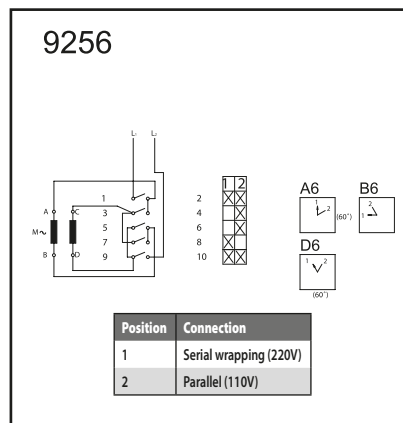
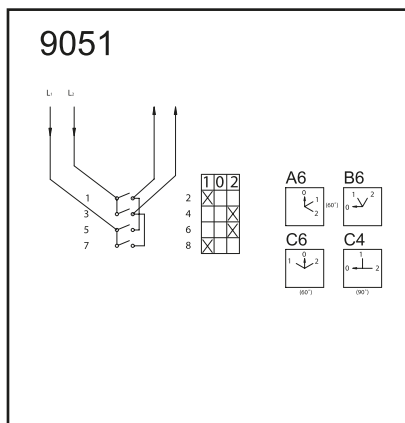

## SWITCHES FOR ONE-PHASE MOTORS

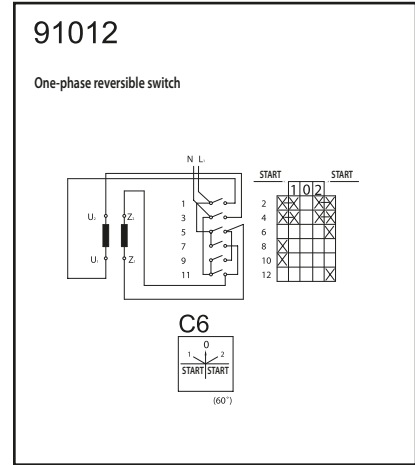
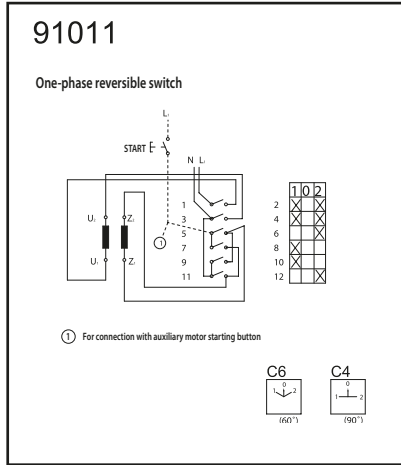
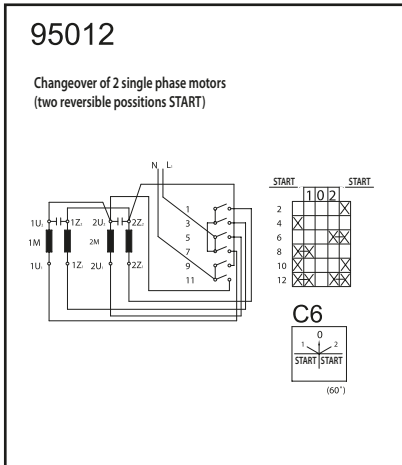

## SYNCHRONOUS MOTORS

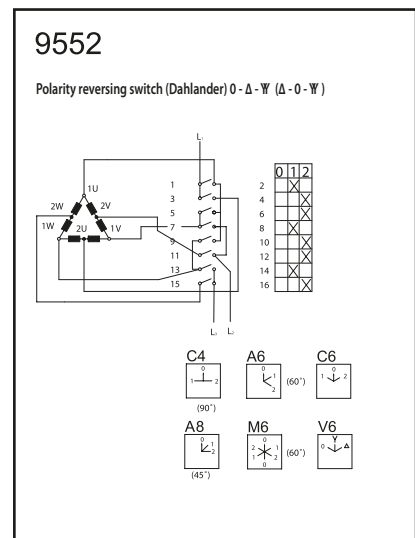
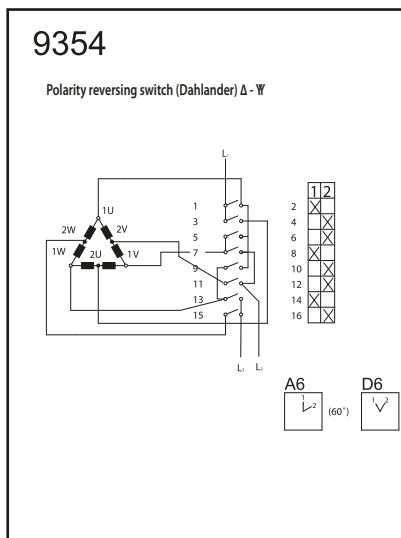
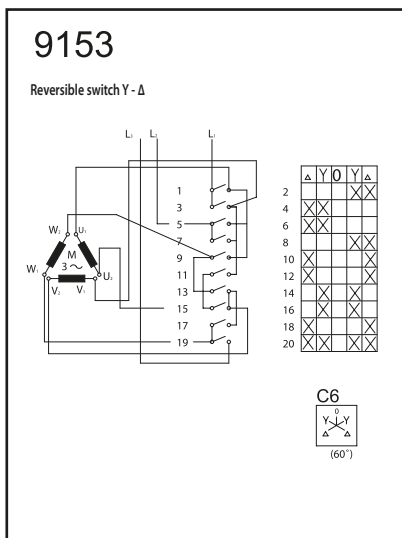
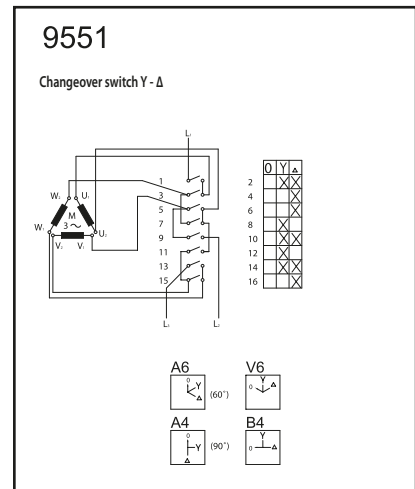
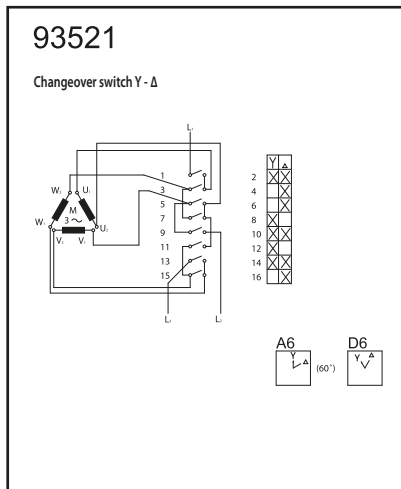
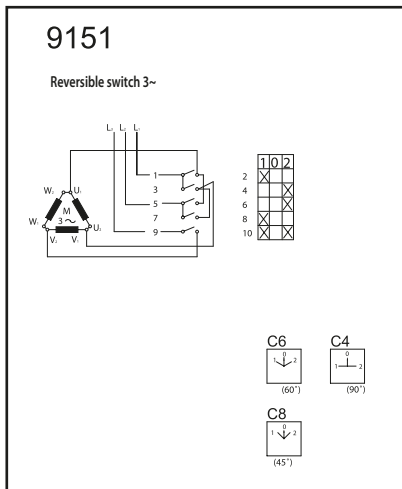



## SWITCHES FOR THREE ASYNCHRONOUS MOTORS

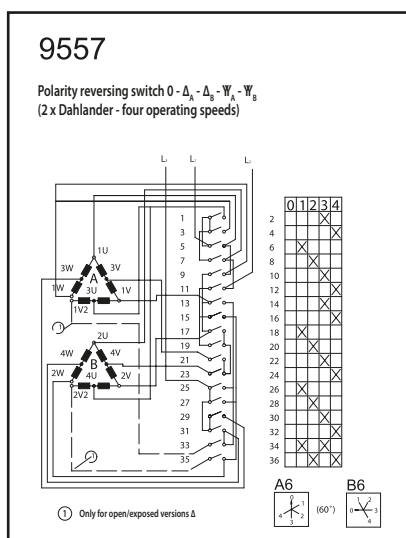
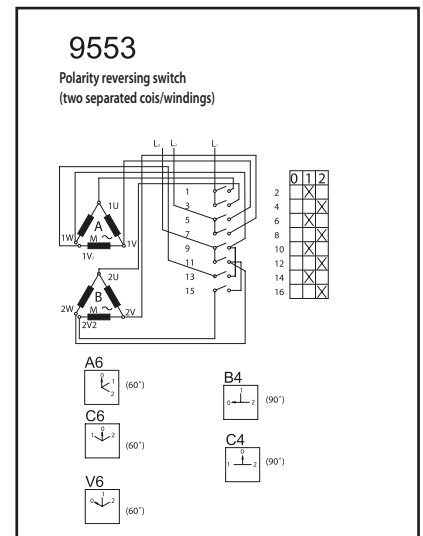
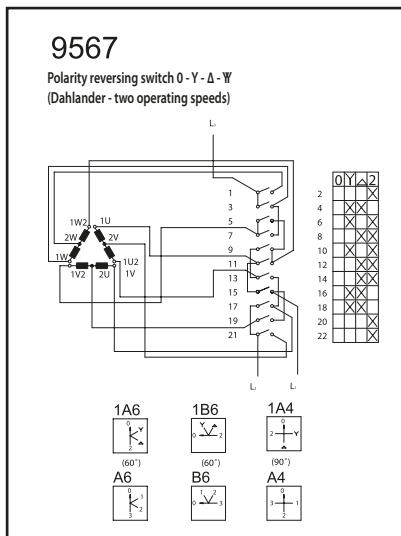
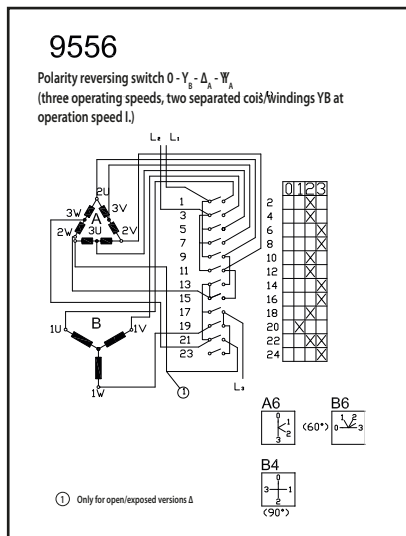
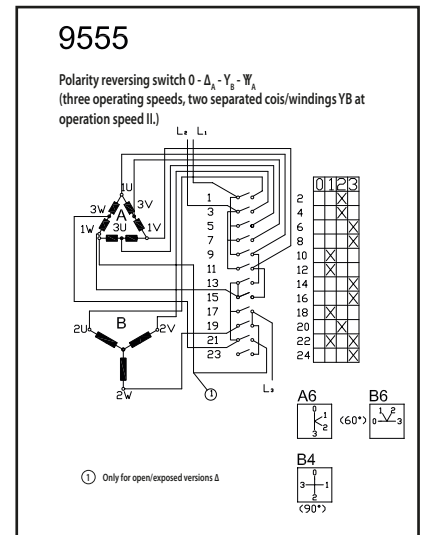
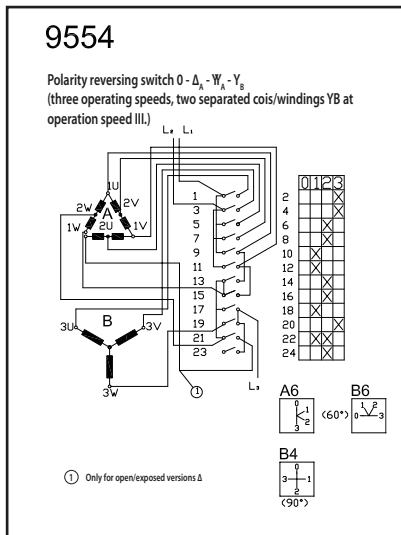
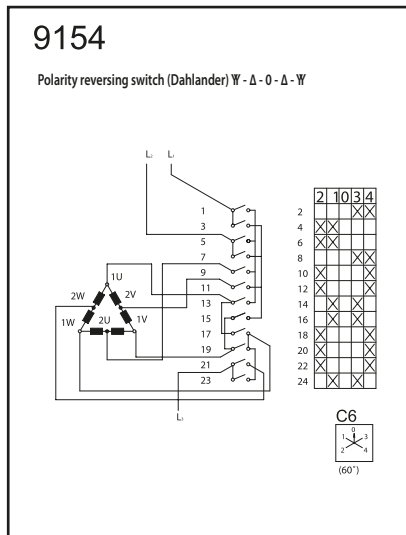

## Description

Switches S 32, 250, 400 J are a new non-conventional designed rotary switch with switching angle 60° with maximum 6 switching positions.

The control gear of the switch is separated from the control switching part of the device and by turning the control lever it enables quick making and breaking contacts independently of the way of control.

The unit-construction switching part of the device has from one to six switching chambers in which there are disks with movable contacts rollers on the basis of Cu and terminal clamps. Maximum number of switching poles is 12.

Minimum use of metal parts in construction of the switch significantly increases the safety of operation.

## Use

They are used for switching unidirectional and alternating electrical circuits till the rated current, and ohmic and inductive load.

## Technical data

- they correspond to EN 60 947-3 (EN 60 947-3, IEC 60 947-3, EN 60 947-3)

		S 32 J		S 250 J	S 400 J
Rated isolation voltage $U_i$ , V		500		660	660
Rated current $I_r$ , A		32		250	400
Rated thermal current $I_{th}$ , A		32		250	400
Rated frequency, Hz		50		50	50
Switching ON/OFF ability, A		v AC 3		v AC 22	v AC 22
		in 500 V		250	450
		in 380 V		250	750
Working current $I_g$ , A		in 500 V		18	150
		in 380 V		25	250
Electric durability, cycles		10.000		1.000	1.000
Mechanical durability, cycles		100.000		10.000	10.000
Class of operational interruption		30		30	30
Working current $I_g$ , A		DC 22 DC 21		DC 22	DC 22
in 110 V=		poles in series	1	6	16
			2	12	20
			3	16	32
in 220 V=		poles in series	1	4	10
			2	6	16
			3	10	20
Connection of conductors, mm <sup>2</sup>		1,5 - 6		240*	240*

\* Possibility to connect cable eye up to Ø 30 mm, for bigger section of the connecting wires is necessary to use additive clamps.

## Mechanical type

Type designation	Execution
S ... J	contact maker/switch with lever
S ... JD	contact maker/switch with front board
S ... JVZ	contact maker/switch with padlocks

## Electrical type

Type	Designation	Marking	No. of switching chambers
S 32 J	Three pole switch	001	2
	Reverse switch	002	3
	Switch YD	003	4
	Reverse switch YD	004	6
	Pole-changing switch	005	4
	Network switch	006	3
S 250, 400 J	One-pole switch	01	1
	Two-pole switch	02	1
	Three-pole switch	03	2
	Four-pole switch	04	2
	One-pole changeover switch	11	1
	Two-pole changeover switch	12	2
	Three-pole changeover switch	13	3
	Four-pole changeover switch	14	4

Other required electric type is necessary to be consult with the producer.

## TYPE DESIGNATION

**S XXX J XX XXX 6/X XXX**

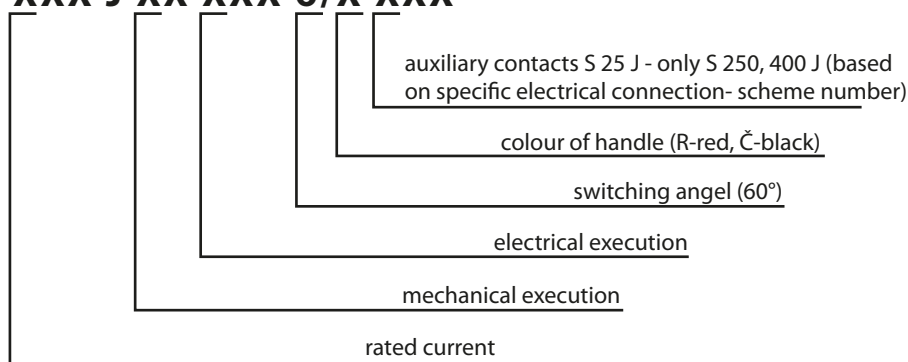

**Notes:** Auxiliary contacts (switch S 25 J) are mounted to the rear side of switches S 250, 400 J.

## Rotary switch S 32 J

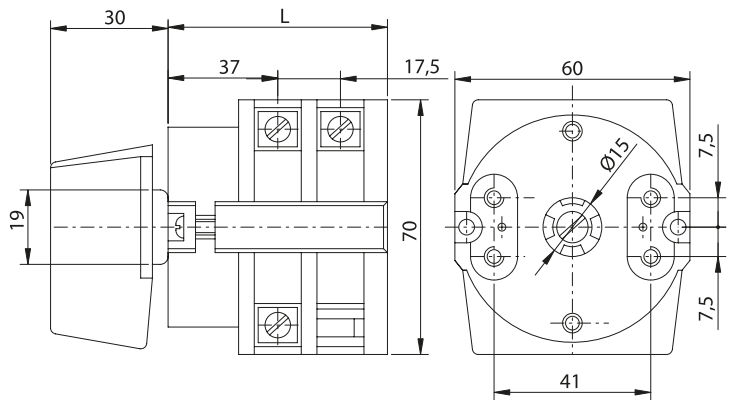
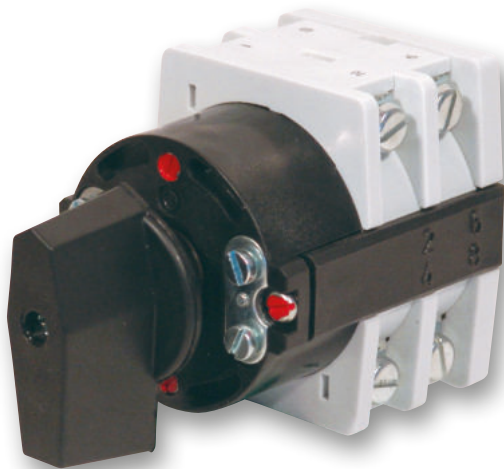

## Rotary switch S 32 JD

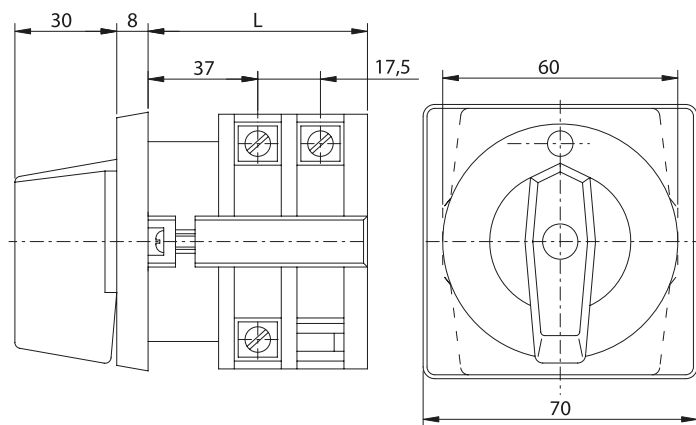

## Rotary switch S 32 JVZ

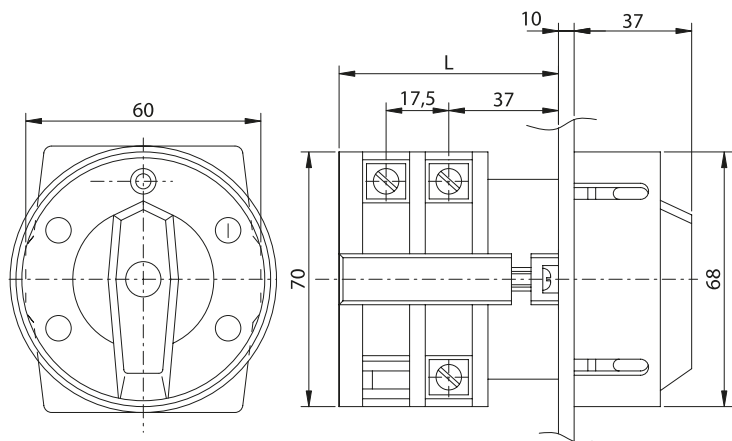
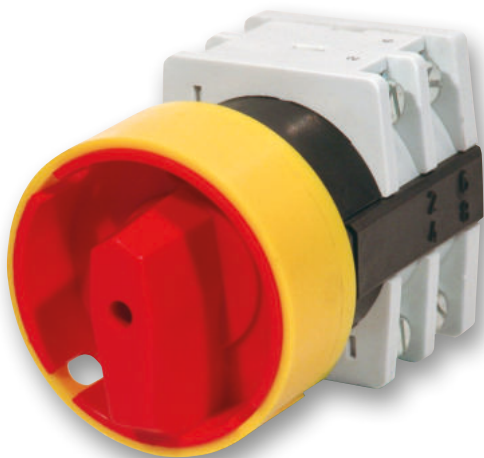

Outlets for switch fitting

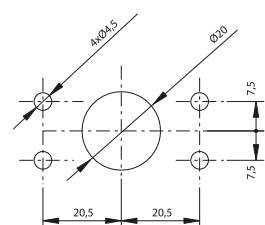

Number of chambers	1	2	3	4	5	6
L	51	68	86	103	121	138

## Rotary switch S 250, 400 J

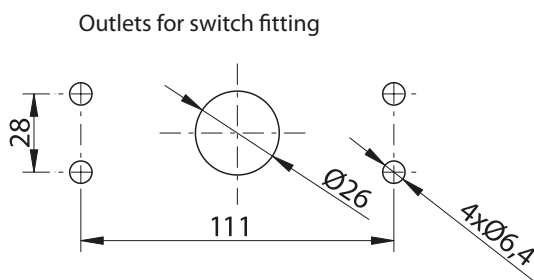
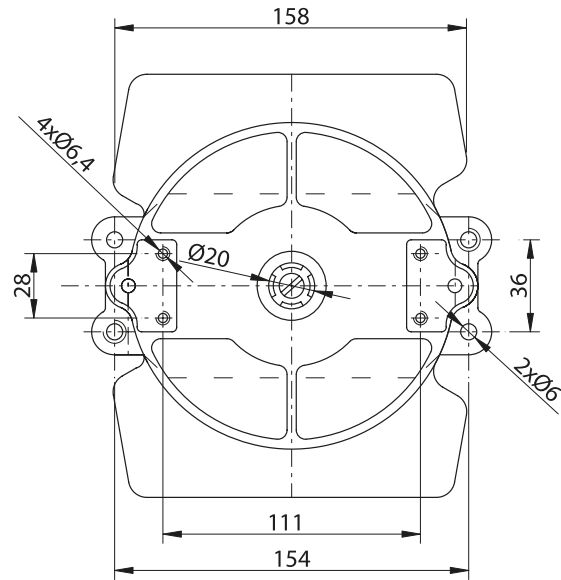
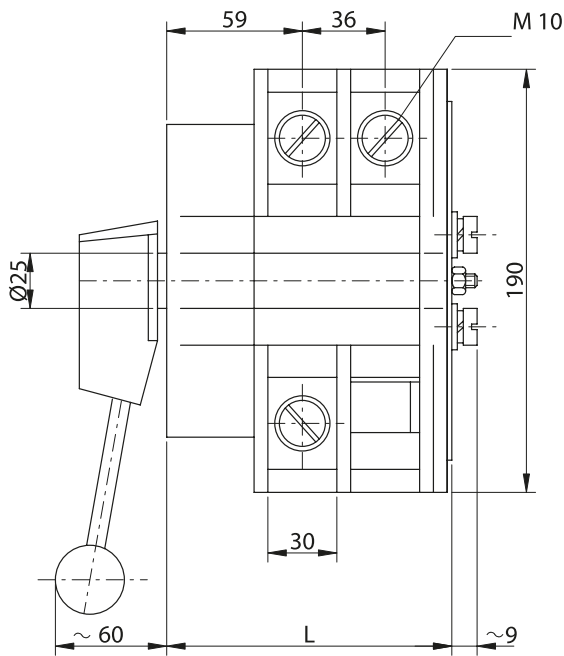

Number of chambers	1	2	3	4
L	88	124	160	196

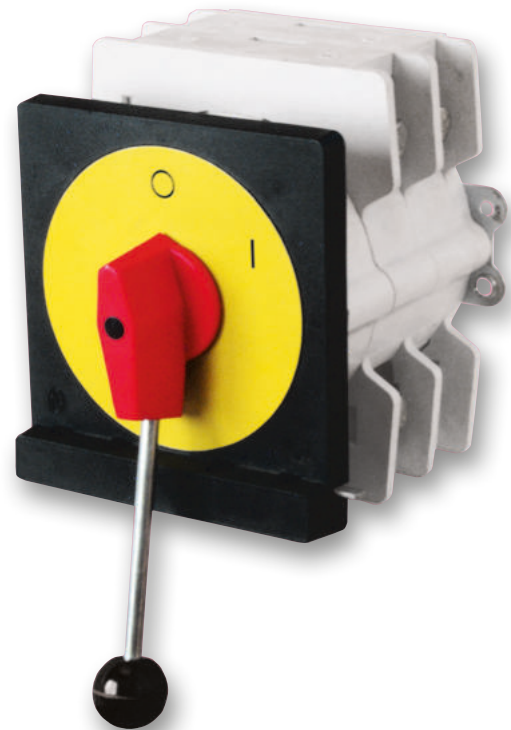

### Fastening:

- to the panel - by four screws M6x10 mm (max) with the axis distance of holes of 28 x 111 mm
- rear - by two screws M6x10 mm (max) with the axis distance of holes of 36 x 154 mm
- frontal plate dimensions of 158 x 172 mm

## Use

Compact power switches K16J and K32J are 2 modules, 3poles switches of rated current 16A and 32A with switching angle 90°. Switches can be mounted on DIN rail, or on base plate with M4 bolts. They can also be mounted on the front panel of distribution box with 2 self tapping screws Ø 3,9. Access to heads of the screws for connection of conductors is in this case from the back side of the switch and the switch is without back fixing rail. O basic execution of 3 poles switches K16J and K32J you can add 4-th and 5-th switching pole, or PE and N poles. These units can be attached to the switches without screws from the left or right side. Extensions front plates of operatings elements, mechanical executions and numeric designation of electrical schemes are identical with cam switches S16J and S25J.

## Example of type designation:

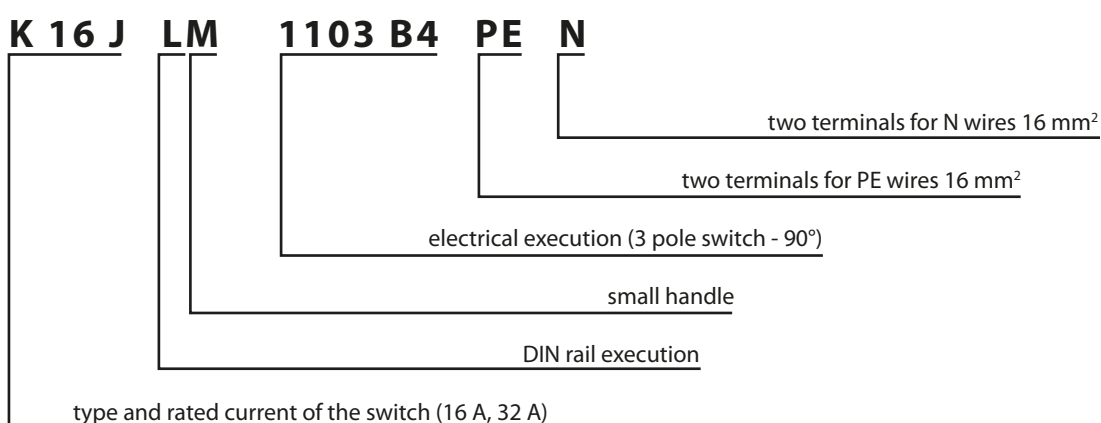

## Technical data

TYPE		<b>K16J</b>	<b>K32J</b>
Standards		STN EN 60947-3	
Rated insulating voltage $U_i$	V	690	690
Rated impulse voltage $U_{imp}$	kV	4	4
Rated thermal current $I_{th} - I_{the}$	A	16	32
Output in AC3 at 500 V~ ( motors )	kW	7,5	11
Rated operating current $I_e$ v AC 23 A – 500 V~	A	16	32
Rated switching-on capacity	A	160	320
Rated switching-off capacity	A	128	256
Conditional short-circuit current with fuse 16, 35 A	kA	6	6
Mechanical endurance		100 000 cykles	100 000 cykles
Max. cross section of conductors	mm <sup>2</sup>	16	16
Protection degree		IP 20	
		IP 40 from the front panel	
Switching angle		90°	
Ambient temperature	°C	-30 till +55	
Mounting		on panel, DIN rail 35 x 7,5	
Rated operating current $I_e$ (A) at DC 22/21	48 V	16	32
	110 V	1	1
	220 V	0,5	0,5

Technical parameters for switching pole SP 16, SP 32 and range of connecting terminals for N32 and N16 are identical with data in chart – Technical data.

Execution:	Type:	Description:
* Switches with rear mounting	K...JLM	- with small handle for DIN rail or with screws
	K...JB	- with control on the door
	K...JP	- in plastic box with IP 65
Switches on panel	K...J	- with handle
	K...JM	- with small handle
	K...JG	- with handle and sealing for IP 65 (also for execution D,U...)
	K...JD	- with handle and front plate
	K...JU	- with lock and 3 padlock - cylindrical
	K...JH	- with locking padlocks on handle
Accessories	K...JF	- with LED signalling diode
	SP 16	- switching pole with terminals 7-8 or 9-10
	SP 32	
	PE 16	- nonswitched pole for two earthing conductors till 16 mm <sup>2</sup>
	PE 32	
	N 16	- nonswitched pole for conductors till 16 mm <sup>2</sup> terminals for central conductors
N 32		

\* For these types there is a possibility of adding front plate and lock with 3 padlocks U, small handle M and handle H.

## Numeric designation of switches:

- 1102 B4 – 2 pole switch
- 1103 B4 – 3 pole switch
- 1104 B4 – 4 pole switch
- 1105 B4 – 5 pole switch

## Application

- 2 to 5 poles switches in AC 21, AC 23 and AC 3 categories (switches for resistive and inductive loads, motors)
- switches in distributions with 3 and 5 conductors with PE a N terminals

## GUIDE FOR AUXILIARY SWITCH SP

Auxiliary switch SP can be mounted to all types of switches K..J, due to increased number of switching poles from three to four or five.

### For correct mounting, following conditions have to be observed:

1. For switches K16J use auxiliary switch SP16, for switches K32J use auxiliary switch SP32
2. Auxiliary switches with terminals marked 7 – 8 are mounted to the right side of switches K..J, auxiliary switches with terminals marked 9-10 to the left side of switches K..J.
3. Auxiliary switches SP with screw head from the front of the device (front of the device is marked with SEZ logo) are intended for attaching on mounting plate or DIN rail, i.e. for switches K..JL. Auxiliary switches with screw head from the back side of the device are intended for switches K..J, i.e. for gripping the switch from the front side.

### Guide for mounting of SP:

1. Put contacts of the switch K..J to the closed position, i.e. handle in position „I“.
2. Slide the auxiliary switch onto switch K..J in the way that projections are directed to apertures of K..J. Slightly push the side of SP and both devices will join together.
3. The function of the device can be checked by changing the position of the handle of the switch to „I“ and „0“ and checking the closing and opening of the contacts of SP.

## GUIDE FOR NON-SWITCHING POLE „N“ AND „PE“

Non-switching pole „N“ and „PE“ can be mounted to all types of switches K..J, , due to increased number of terminals of the switch K..J for gripping the conductors N and PE.

### For correct mounting, following conditions have to be observed:

1. For switches K16J use non-switching pole N16 or PE16 and for switches K32J use non-switching pole N32 or PE32.
2. Non-switching poles with terminals marked N-N are mounted to the right side of switches K..J, non-switching poles with terminals marked PE-PE to the left side of switches K..J.
3. Non switching poles N a PE with screw head from the front of the device (front of the device is marked with SEZ logo) are intended for attaching on mounting plate or DIN rail, i.e. with marking of the switch K..JL. Non-switching poles with screw head from the back side of the device are intended for switches K..J, i.e. for gripping the switch from the front side.

### Guide for mounting of N a PE:

Slide the non-switching pole N, or PE onto the switch K..J in the way that projections are directed to apertures of K..J. Slightly push the side of N or PE and both devices will join together.

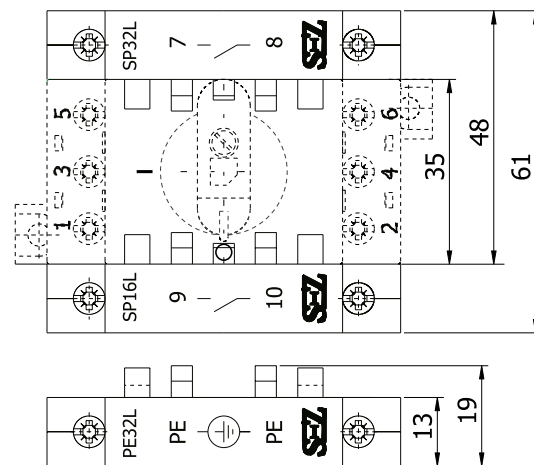
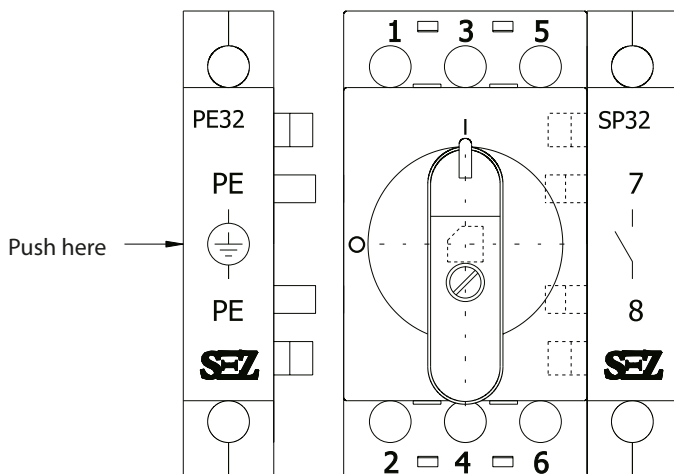
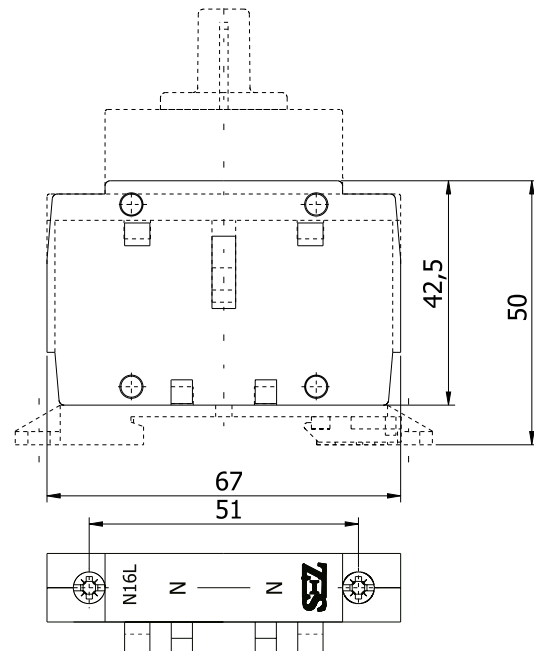



## Dimensional drawing

**K 32 J**

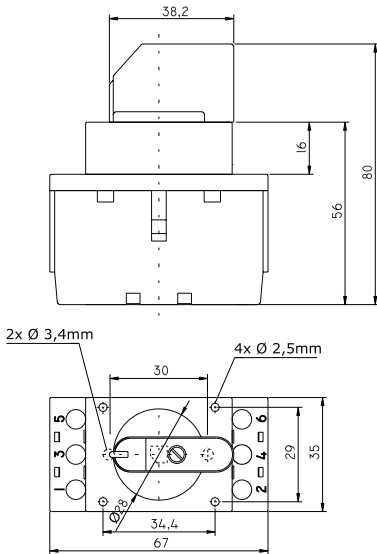

**K 32 JDM**

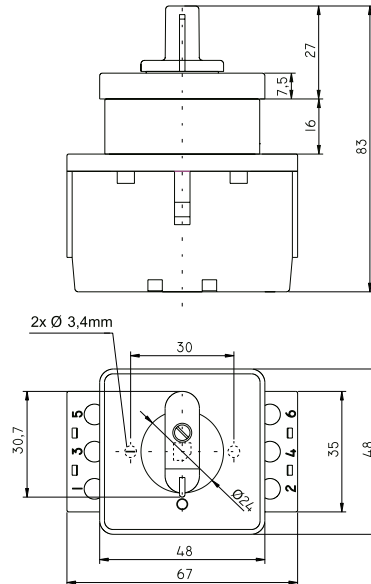

**K 32 JLU**

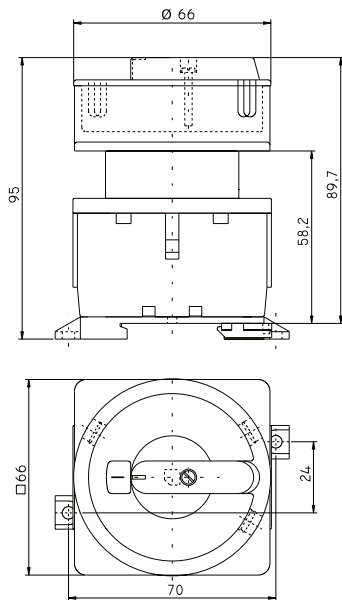

**K 32 JPU**

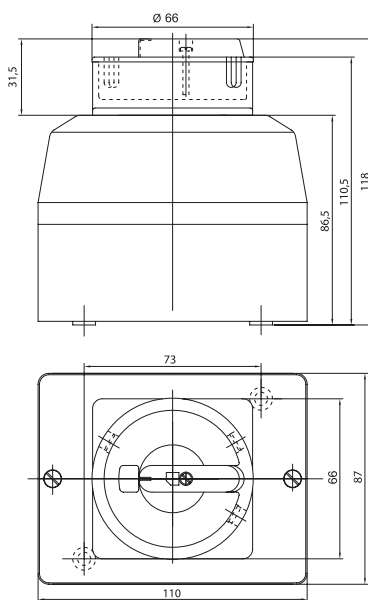

**K 32 JLM**



**K 32 JU**



**K 32 JM**



**K 32 JD**



**K 32 JLU**



**K 32 JPM**



## FOR CAM SWITCHES S 63 - 160 J

### Winch 6x6

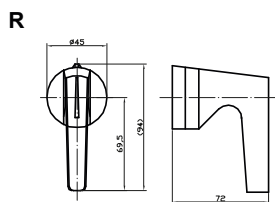
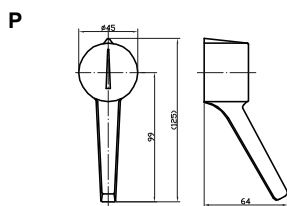
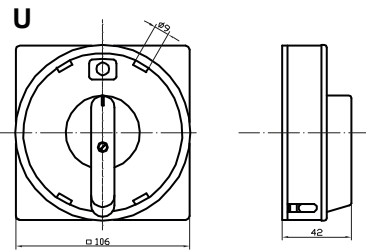
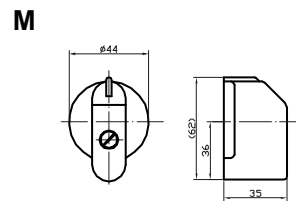
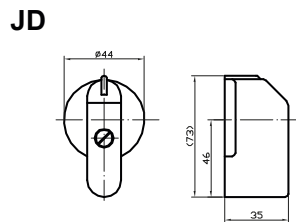
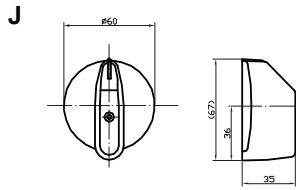

## FOR CAM SWITCHES S 6 - 40 J, SWITCHES K 16 - 32 J

### Winch 5x5

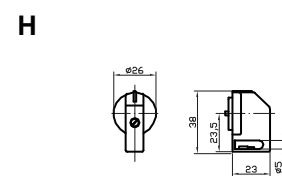
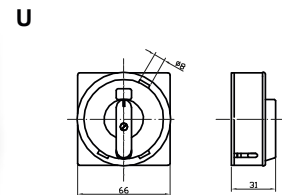
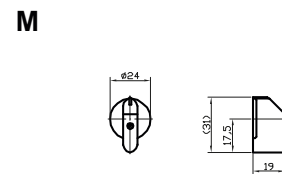
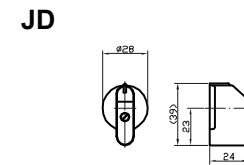
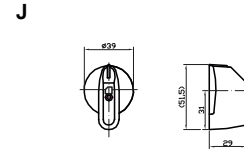

### TABLE OF THE ORDERING NUMBERS FOR SPARES PARTS FOR SWITCHES

handle name	symbol	Ordering number			
		Switches S 63 - 160 J		Switches S 6 - 40 J K 16 - 32 J	
		black	red	black	red
middle handle	J	1100846	1100847	1100870	1100871
middle handle	JD	1010500	1101550	1100524	1100525
small handle	M	1105982	1105983	1029002	1029003
handle for locking cilindric	U	1005901	1104774	1100436	1100437
handle for locking small	H	-	-	1029000	1029001
big handle	P	1033014	-	-	-
handle holder	R	1033016	-	-	-

**Note:** In type sign of cam switches is signed of the red handle - R

## SWITCHES IN EMBEDDED BOX S25JEP, K32JEP

### Description and technical data:

- switch in plastic box designed to be used for connection of electric heaters, boilers etc.
- can be used in household or in industry
- protection IP 65, clamps and contacts are protected from the event of direct connection with protection degree IP 20
- box installation into panel, wall, etc.
- there is possibility to add two pairs of two cable bushings Pg16 or Pg21, which are not a part of basic product package
- in accordance STN EN 60 947-3 (EN 60947-3, IEC60947-3, ČSN EN60947-3)
- variants:
  - S25JEPF with cam switch and signal lamp
  - S25JEP with cam switch
  - K32JEPF with cam switch and signal lamp
  - K32JEP with cam switch
- colour variant:
  - white
  - 1-dark brown
  - 2-tawny(beige)
  - 3-black

### Other colour variants possible

Switch type	S 25 JEP	K 32 JEP
Rated insulation voltage $U_i$ (V)	500	690
Rated impulse withstand voltage $U_{imp}$ (kV)	4	4
Rated thermal current $I_{th}$ (A)	25	32
Rated operating power kW AC3/AC23 400V, 500V	7,5/11	11
Rated operating current $I_e$ (A) AC23	400V	32
	500V	32

## S 25 JEPF 1103 B4 - 1

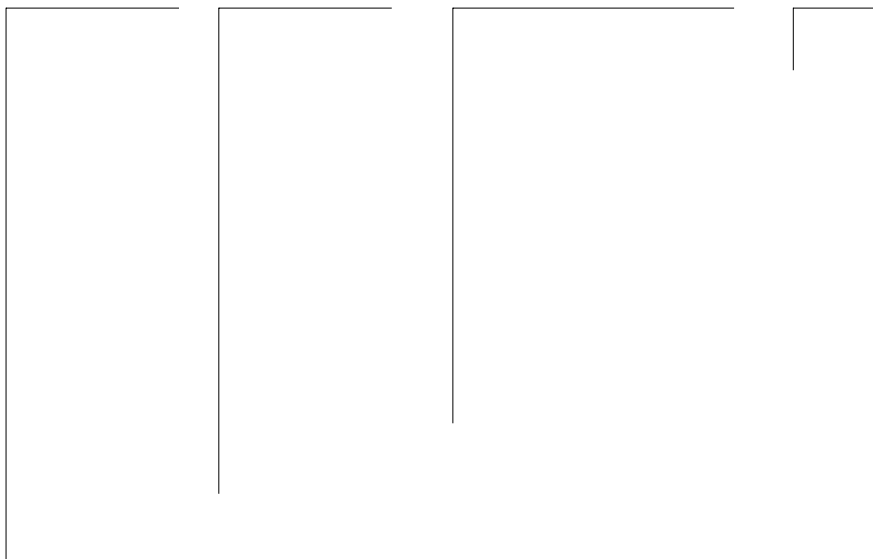

## Switches in embedded box S25JEP, K32JEP

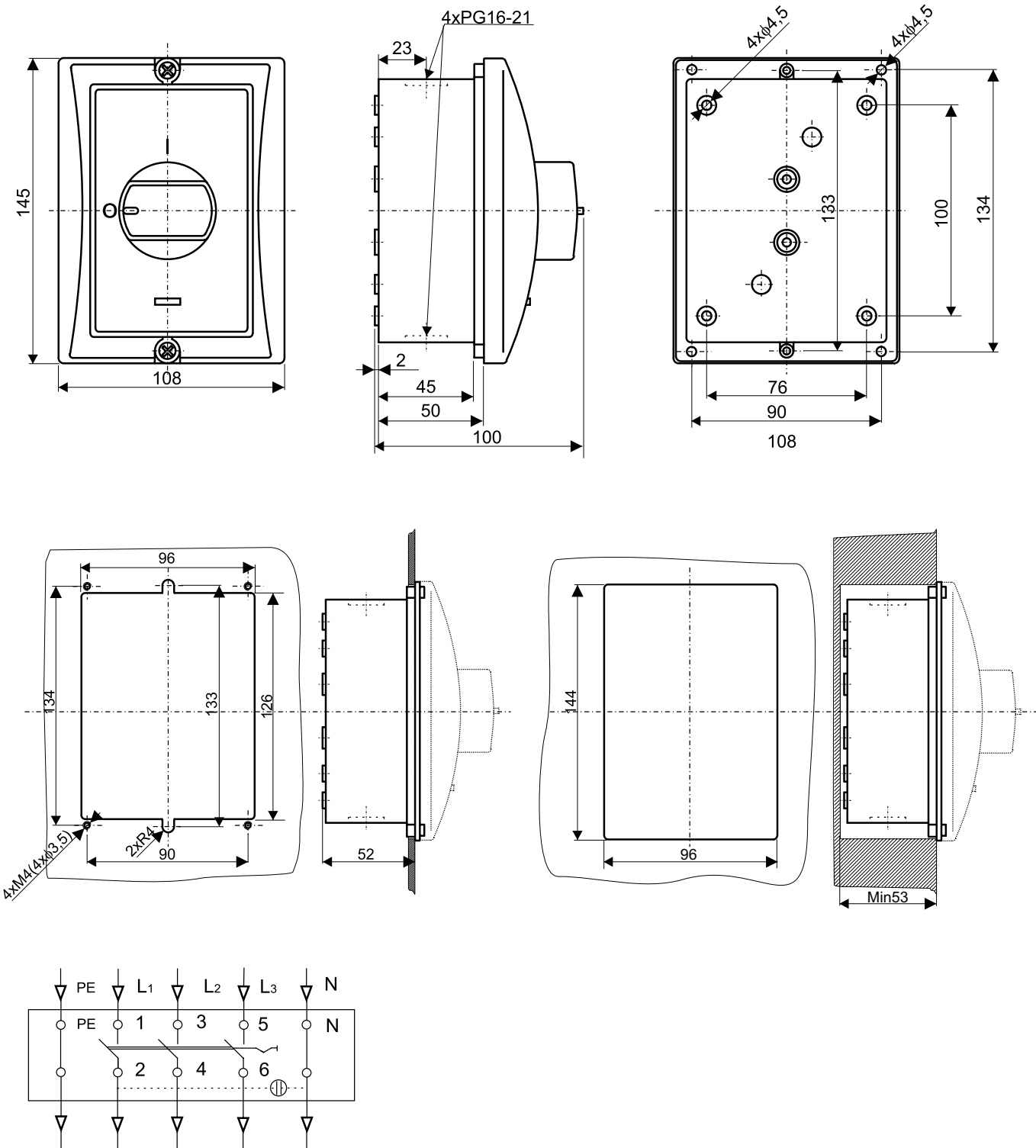

## Description and technical data:

- switch in plastic box with special lever
- protection IP 65, clamps and connections are protected against contact with degree of protection IP 20
- fixation on the base with 2 screws M4
- two cable terminals are part of delivery: Pg 16 for S10 – 16 JPS, Pg 21 for S25 JPS
- they are in accordance with STN EN 60947-3(EN 60947-3, IEC 60947-3, ČSN 60947-3), STN EN 60204-1, VDE 0606
- they are in accordance with T 32 and temperatures of ambient -30°C - +55 °C
- possibility delivery of switches by the specification of customer

Type		S10J	S16J	S25J
Rated voltage $U_i$ (V)*		690**	690**	690**
Rated impulse withstand voltage $U_{imp}$ (kV)		4	4	4
Rated thermal current $I_{th}$ (A)		10	16	25
Rated operational current $I_e$ (A), AC-21A, AC-1				
AC - 3, short circuit armature motors	1 phase 220 - 240 V	1,5/8,5	1,7/9,6	2,6/14,7
	3 phase 220 - 240 V	2,5	3	4,5
	380 - 400 V	3,5/6,3	4/7,2	7,5/13,5
	500 V	3,5	4	7,5
AC - 23, switching the motors and high inductive loads	1 phase 220 - 240 V	1,7/9,6	2,3/13	3/17
	3 phase 220 - 240 V	3	4	5,5
	380 - 400 V	6/10,8	7,5/13,5	11/19,8
	500 V	6	7,5	11

STN 330420- valid for mains with grounded neutral point, category of overstrain III. And degree of contamination 2,  $U_i = 500V$  if degree of contamination is 3.

## The most common electric scheme of switching.

S...JPS 0103 044 C4

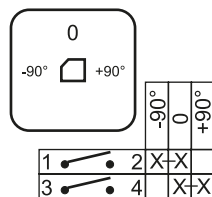

S...JPS 0203 275 C4

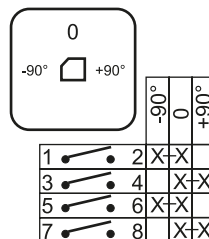

S...JPS 0104 048 A4

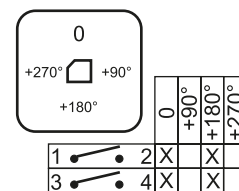

S...JPS 0204 277 A4

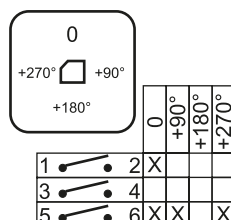

S...JPS 0204 278 A4

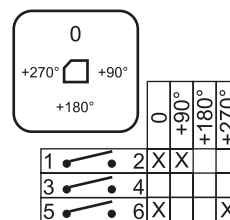

S...JPS 0205 271 C4

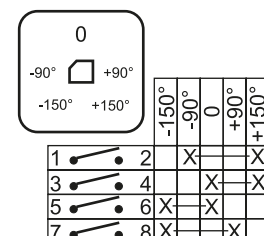

Possibility to adjust switches according to specification of customer

